

PARALLEL GRIPPERS

PH SERIES

STANDARD LINE

- Full range of sizes and strokes
- Adjustable finger stroke
- Robust design
- Durable construction with few moving parts
- Top and side mounting
- Optional cap styles
- Sensors Available

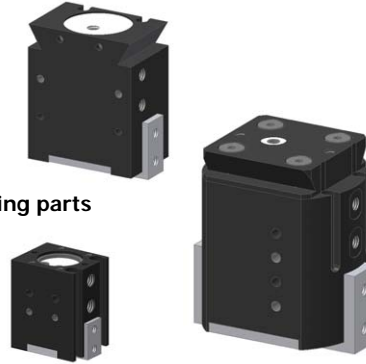

See Page **1-1.2**



Miniature Parallels

LP SERIES

LOW PROFILE - WIDE STROKE

- Full range of sizes and strokes
- Robust design
- Extremely Durable construction
- Precision Top and side mounting
- Sensors ready

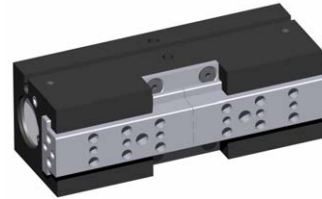

See Page **1-1.20**



PH-20

STACKABLE

- Small center-to-center distance
- Adjustable finger stroke
- Robust design
- Durable construction with few moving parts
- Top and side mounting



See Page **1-1.27**

JF-20

WIDE BODY

- Large stroke
- Adjustable finger stroke
- Robust design
- Durable construction with few moving parts
- Top and side mounting

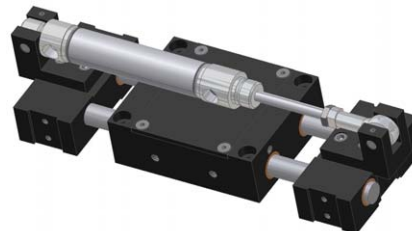

See Page **1-1.33**



PH-SERIES

DURA-GRIP PH Series of Part Placement Devices is designed to provide a low cost gripping unit for use on transfer mechanisms. These air operated units grip parts internally or externally offering the designer a wide latitude in finger tooling arrangements. All units are shipped completely assembled, ready for mounting and attaching tooling.

QUALITY CONSTRUCTION

DURA-GRIP PH Series is ruggedly constructed with a minimum of moving parts. The body is hard coated, high strength aluminum and the fingers are hardened steel. A full range of finger strokes and gripping forces are available throughout the series. Both finger opening and closing position can be adjusted on the unit.

MOUNTING INFORMATION

DURA-GRIP PH Series can be mounted in any plane with standard dovetail or mounting holes on top, front and back of unit. These same holes can also be used to mount "stripper" devices. Optional Dowel holes (-D option) provide precision location of the units. Additional flat top cap styles are also available if dovetail is not necessary.

OPTIONAL FEATURES

Single Finger heads are available with either the left or right finger fixed and the other moving (-SFR or -SFL). Optional Magnetic or Inductive sensors are available on all heads. The sensors can be used to indicate finger position.

Use the PH Series of Parallel Grippers wherever you need durable and precise part placement.



PH-5 / PH-10



STROKE
0.125" [3.17mm]
to 0.187" [4.75mm]

See Page **1-2.4**

PH-30 / PH-40

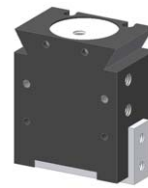

STROKE
0.250" [6.35mm]

See Page **1-2.8**

PH-50 / PH-60



STROKE
0.400" [10.2mm]
to 0.520" [13.2mm]

See Page **1-2.13**

PH-70

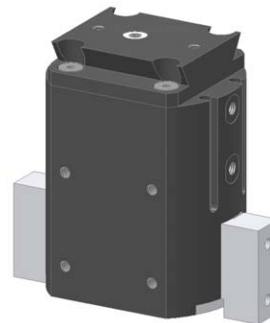

STROKE
1.000" [25.4mm]

See Page **1-2.17**

TECHNICAL SPECIFICATION

Pneumatic Specifications	ENGLISH	METRIC
Pressure Range	40-100 psi	3-7 bar
Cylinder Type	Double Acting	
Dynamic Seals	Buna-N	
Required Valves	4-way, 2 position	
Normal Cycle Life	20+ Million	
Temperature Range		
Buna-N Seals (standard)	-30 to 180 F	-35 to 80 C
Viton Seals (-V option)	-20 to 300 F	-30 to 150 C

OPERATING PRINCIPLES - STANDARD UNIT

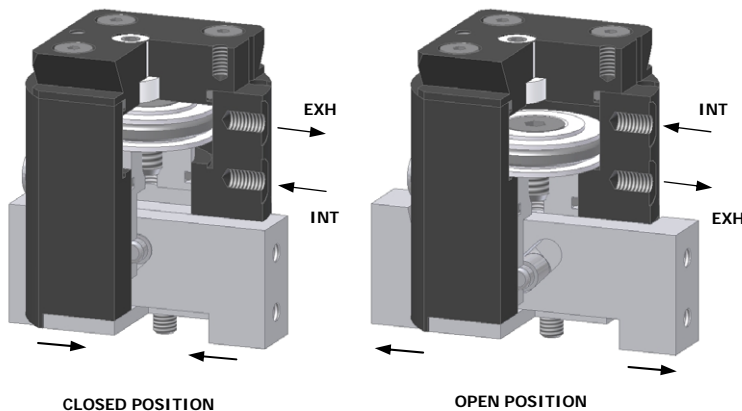

- Air pressure drives double acting piston.
- Piston drives fingers through precision slots producing synchronized parallel motion.
- Gripper is capable of external and internal gripping



CLOSE ADJUSTMENT

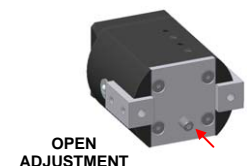

OPEN ADJUSTMENT

Finger closed and open position can be adjusted with set screws located in the bottom and top cap of the unit.

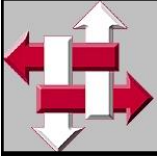

PRODUCT FEATURES

- Aircraft Grade Aluminum with black Hard coat
- Simple and Highly Durable Time tested, field approved design
- High Grip Force High gripping force-to-weight ratio

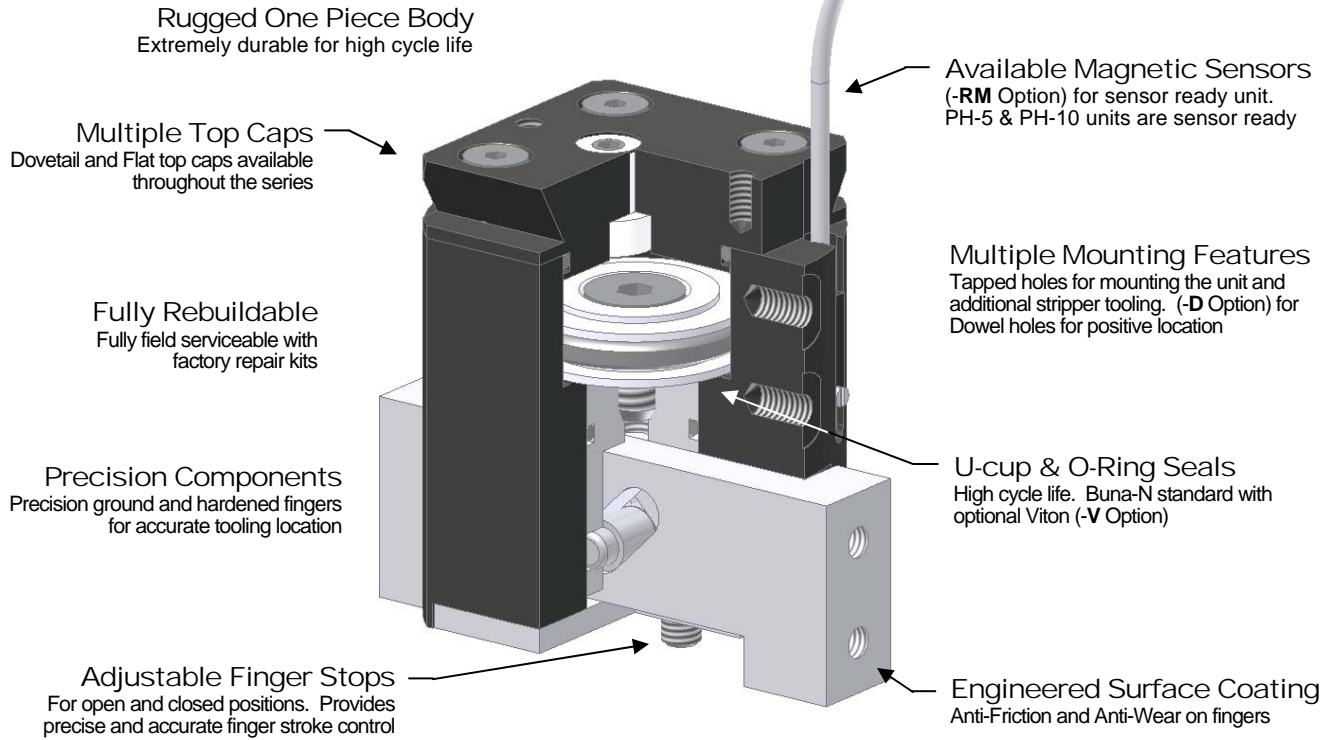

DESIGNED - MANUFACTURED - ASSEMBLED IN THE USA

MOUNTING INFORMATION

Mounts and operates in any orientation

MAIN BODY

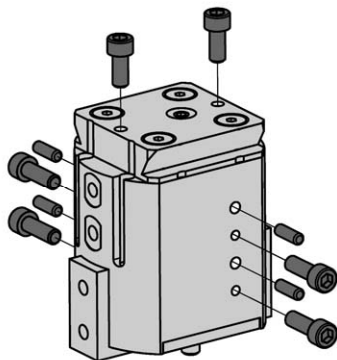

Mount up to Main body utilizing Dovetail or Tapped holes located on back, front, and top.

(-D) Option provides precision Dowel holes on the front and back side of the unit for positive location.

Mounting features vary, see product pages for specific mounting information

Additional Flat top cap available for a variety of mounting styles. See product pages for more information

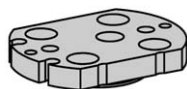

Flat Top Cap

TOOLING

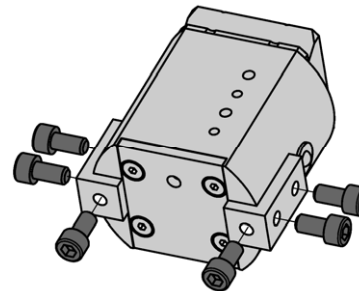

Mount tooling to fingers using Tapped holes located on the bottom and sides of fingers

Key tooling to precision ground fingers for positive location.

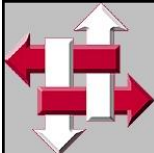

R&I
MANUFACTURING CO.

DURA-GRIP
PARALLEL GRIPPER



PH-5

DIMENSIONAL DRAWING

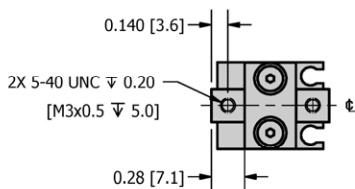
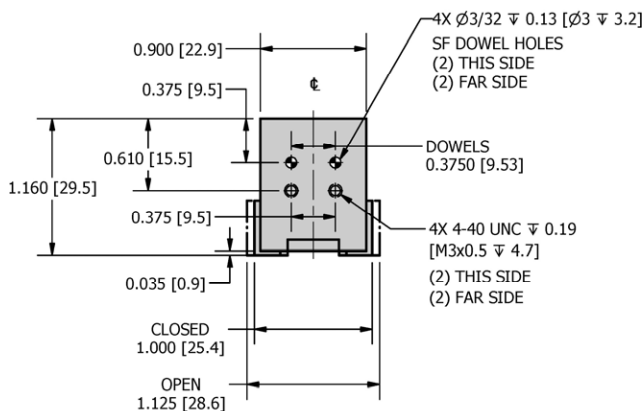
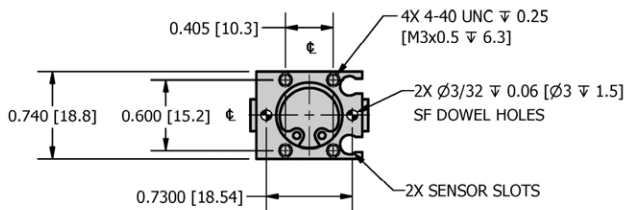

SPECIFICATIONS

	PH-5	MPH-5
Standard Grip Force @ 100 psi [7 bar] *	6 lbf	26 N
Standard Stroke	0.125 in	3.1 mm
Base Weight	0.09 lbs	0.04 kg
Unit Displacement (grip and release)	0.015 in ³	0.24 cm ³
Cylinder Bore Diameter	0.437 in	11.09 mm
Actuation Time (no load)	0.14 sec	

* Loading between lower jaw surface - zero tooling length

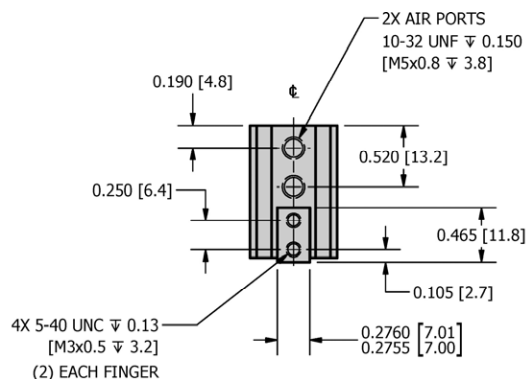

LOADING

	PH-5		MPH-5	
	Static	Dynamic	Static	Dynamic
Max Force F	25 lbf	4 lbf	111 N	17.8 N
Max Moment M_{x,y,z}	15 lbf-in	2.5 lbf-in	1.7 N-m	0.3 N-m

NOTE: Loading based on utilization of both fingers

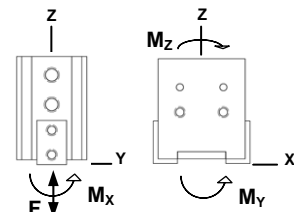

HOW TO ORDER : BASIC UNIT

METRIC

M **PH-5** - **V**

SEALS

METRIC M

SEALS V - Viton (standard Buna - N)

SAMPLE ORDER: PH-5-V

Ex) PH-5 With Viton seals

**CUSTOM DESIGNS ALWAYS AVAILABLE
PLEASE CONTACT US FOR INFORMATION**

ACCESSORIES (order separately)

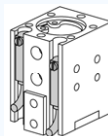

PH-5 units are sensor ready for use with the sensors listed below

MAGNETIC SENSOR KITS (Round track mounted)

RSK-N - Magnetic Sensor NPN w/ quick disconnect Kit
RSK-P - Magnetic Sensor PNP w/ quick disconnect Kit

MAGNETIC SENSORS (Round track mounted)

RS-N - Magnetic Sensor NPN w/ quick disconnect
RS-P - Magnetic Sensor PNP w/ quick disconnect

SENSOR CABLE

SENCAB-5 - Quick Disconnect PUR Cable 5M Length

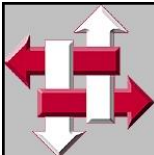

R&I
MANUFACTURING CO.

DURA-GRIP
PARALLEL GRIPPER



PH-10



DIMENSIONAL DRAWING

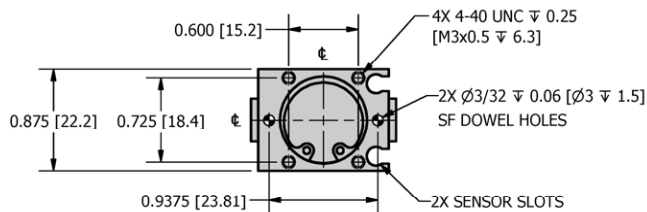

SPECIFICATIONS

Standard Grip Force @ 100 psi [7 bar] *
Standard Stroke
Base Weight
Unit Displacement (grip and release)
Cylinder Bore Diameter
Actuation Time (no load)

	PH-10	MPH-10
Standard Grip Force @ 100 psi [7 bar] *	12 lbf	53 N
Standard Stroke	0.187 in	4.7 mm
Base Weight	0.15 lbs	0.07 kg
Unit Displacement (grip and release)	0.05 in ³	0.77 cm ³
Cylinder Bore Diameter	0.625 in	15.88 mm
Actuation Time (no load)	0.16 sec	

* Loading between lower jaw surface - zero tooling length

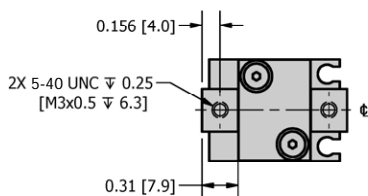
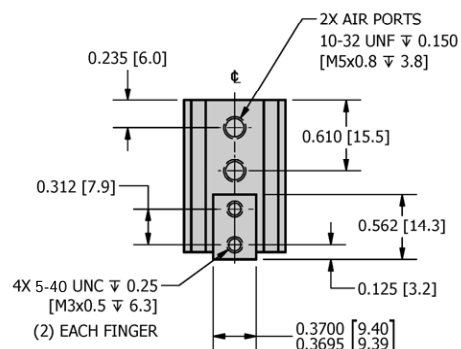
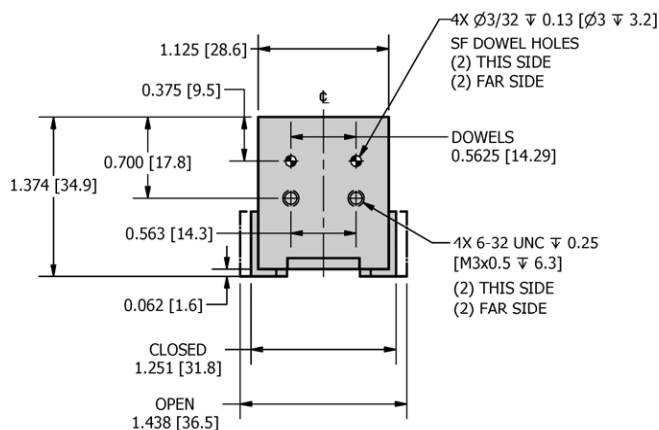

LOADING

	PH-10		MPH-10	
	Static	Dynamic	Static	Dynamic
Max Force F	50 lbf	8 lbf	222 N	35 N
Max Moment M_{x,y,z}	30 lbf-in	5 lbf-in	3.4 N-m	0.6 N-m

NOTE: Loading based on utilization of both fingers

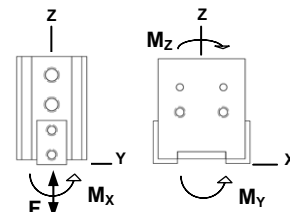

HOW TO ORDER : BASIC UNIT

METRIC

M **PH-10** - **V**

SEALS

METRIC M

SEALS V - Viton (standard Buna - N)

SAMPLE ORDER: MPH-10

Ex) Metric PH-10

**CUSTOM DESIGNS ALWAYS AVAILABLE
PLEASE CONTACT US FOR INFORMATION**

ACCESSORIES (order separately)

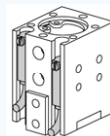

PH-10 units are sensor ready for use with the sensors listed below

MAGNETIC SENSOR KITS (Round track mounted)

RSK-N - Magnetic Sensor NPN w/ quick disconnect Kit
RSK-P - Magnetic Sensor PNP w/ quick disconnect Kit

MAGNETIC SENSORS (Round track mounted)

RS-N - Magnetic Sensor NPN w/ quick disconnect
RS-P - Magnetic Sensor PNP w/ quick disconnect

SENSOR CABLE

SENCAB-5 - Quick Disconnect PUR Cable 5M Length

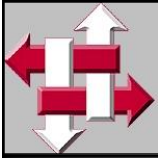

ADDITIONAL INFORMATION

GRIP FORCE

The maximum capacity of the gripper is a function of many variables and will change based on the shape of the part, surface finish, accelerations during transfer, the shape of the finger tooling, and air pressures. Use the Grip force calculated below *and* the application variables to determine the proper sizing of the gripper.

The Grip force - **F** is defined as the maximum force that can be applied to the fingers without moving. The force is analytically determined and will vary slightly with friction.

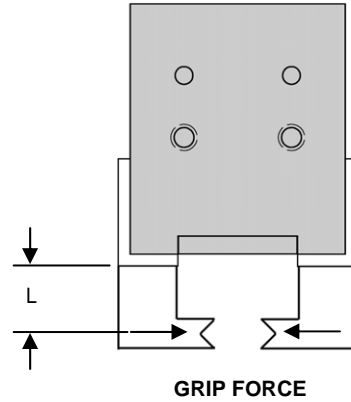

English **GRIP FORCE - F (lbf) = P_{AIR} (psi) x G_F x T_F**
 Metric **GRIP FORCE - F (N) = P_{AIR} (bar) x G_F x T_F**

P_{AIR} = Air Pressure
G_F = Grip Factor (see chart)
T_F = Tooling Factor (see graph)



It is recommended that finger tooling be designed to encompass the part as the grip force requirement is lower. If the grip cannot be performed by encompassing the part and a friction grip must be performed, always use a factor of safety of at least 4.

GRIP FACTOR G_F		PH-5	MPH-5
Standard Unit	EXTERNAL	0.058	3.73
	INTERNAL	0.034	2.19

GRIP FACTOR G_F		PH-10	MPH-10
Standard Unit	EXTERNAL	0.119	7.67
	INTERNAL	0.076	4.89

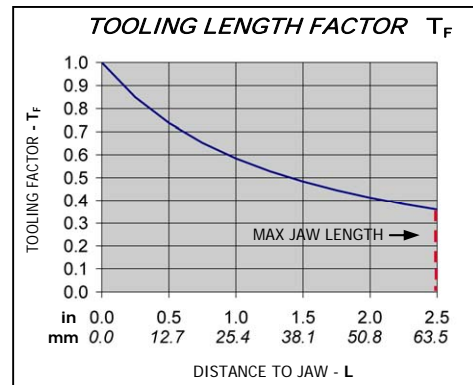
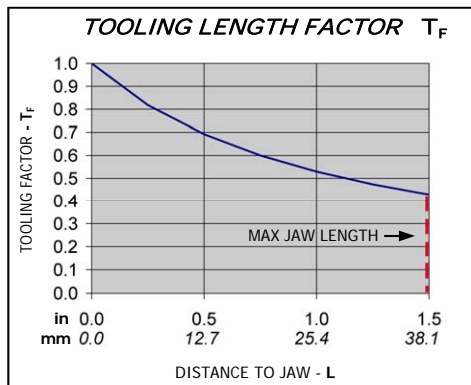

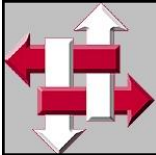

R&I
MANUFACTURING CO.

DURA-GRIP
PARALLEL GRIPPER

PH-5/10

EXPLODED VIEW

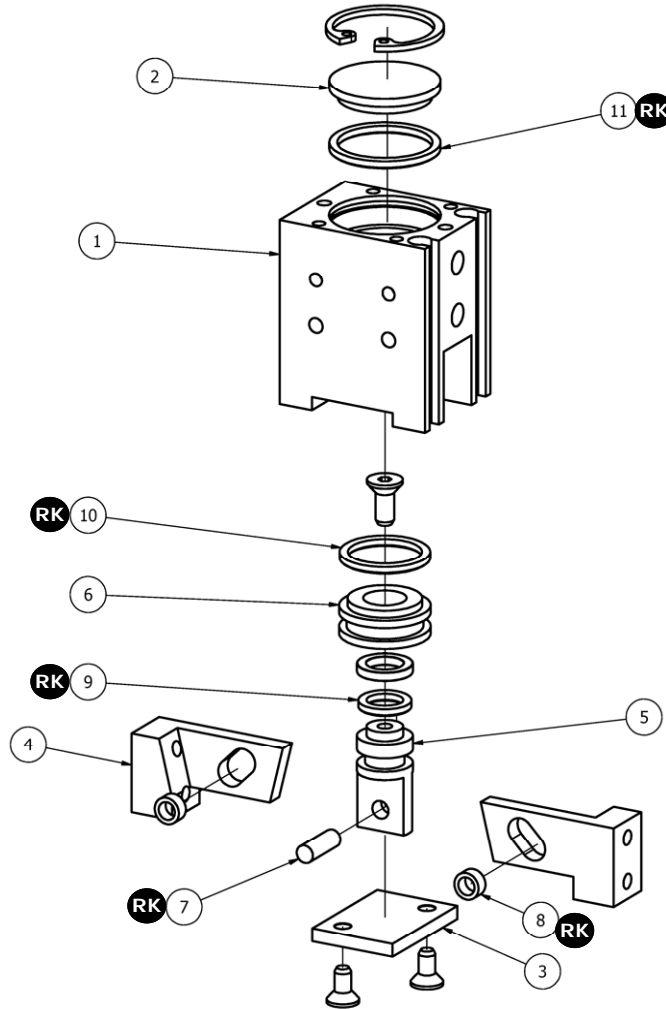

PARTS LIST

HOW TO ORDER PARTS

ITEM	REQ'D	NAME	PH-5	PH-10	OPTIONS
1	1	Body	PH-5-1	PH-10-1	
2	1	Cylinder Cap *	PH-5-2	LP-100-6	
3	1	Bottom Cap	PH-5-3	PH-10-3	
4	2	Finger	PH-5-4	PH-10-4	
5	1	Piston Shank	PH-5-5	PH-10-5	
6	1	Piston	PH-5-6	PH-10-6	
7	1	Pin *	PH-5-7	PH-10-7	
8	2	Roller *	PH-5-8		
9	1	Piston Shank Seal *	ORG-008	ORG-010	-V ¹
10	1	Piston Seal *	ORG-011	ORG-014	-V ¹
11	1	Cylinder Cap Seal *	ORG-013	ORG-016	-V ¹
RK	1	Repair Kit * #	PH-5-RK	PH-10-RK	-V ¹

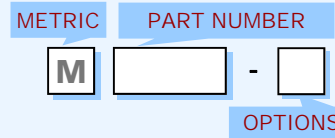

SAMPLE ORDER: PH-5-1

Ex) PH-5 Body

OPTIONS (see product pages for information)

¹ - V = Viton

NOTES

* - Metric code not required

- Repair Kits include req'd qty of parts marked with RK

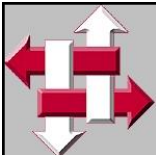

DIMENSIONAL DRAWING

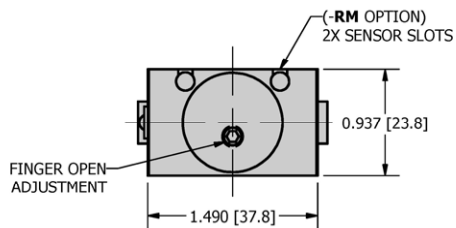

SPECIFICATIONS

	PH-30	MPH-30
Standard Grip Force @ 100 psi [7 bar] *	21 lbf	93 N
Standard Stroke	0.25 in	6.4 mm
Base Weight	0.31 lbs	0.14 kg
Unit Displacement (grip and release)	0.12 in ³	1.9 cm ³
Cylinder Bore Diameter	0.875 in	22.2 mm
Actuation Time (no load)	0.20 sec	

* Loading between lower jaw surface - zero tooling length

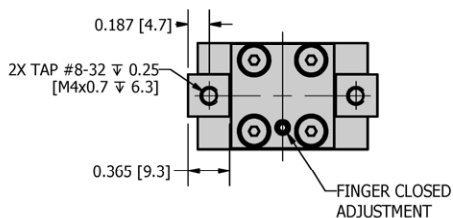
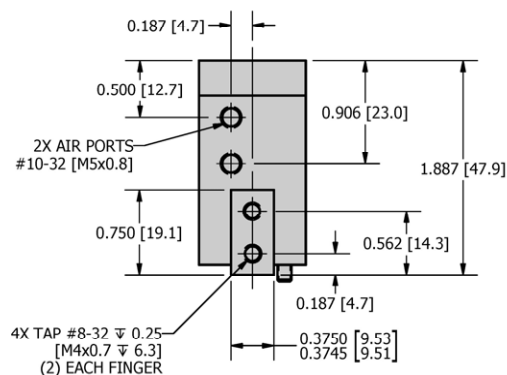
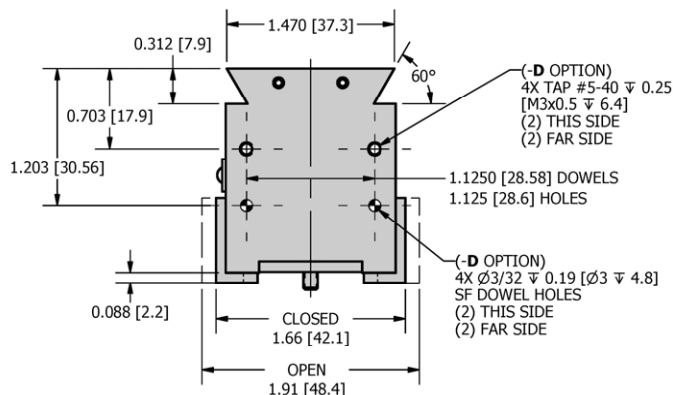

LOADING

	PH-30		MPH-30	
	Static	Dynamic	Static	Dynamic
Max Force F	100 lbf	20 lbf	444.5 N	88.9 N
Max Moment M_{x,y,z}	75 lbf-in	15 lbf-in	8.5 N-m	1.7 N-m

NOTE: Loading based on utilization of both fingers

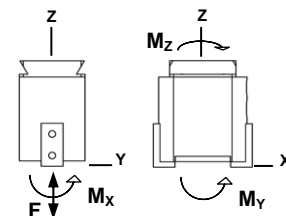

HOW TO ORDER : BASIC UNIT

ACCESSORIES (order separately)

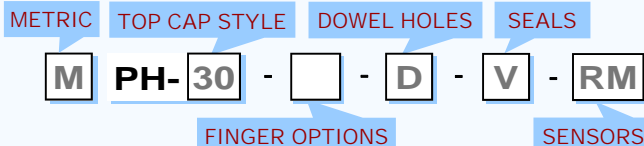

METRIC M

TOP CAP 30 - 60° Dovetail (shown above)
31 - Flat (see additional information section)

FINGER OPTIONS SFR - Stationary Right Finger
SFL - Stationary Left Finger (oilier side)

DOWEL HOLES D - Dowel Holes for positive location of unit
Includes tapped mounting holes

SEALS V - Viton (standard Buna - N)

SENSORS RM - Magnetic Sensor Ready
Includes Sensor slots and Piston Magnet. Sensors sold separately - see Magnetic Sensors

MAGNETIC SENSOR KITS * (Round track mounted)

RSK-N - Magnetic Sensor NPN w/ quick disconnect Kit
RSK-P - Magnetic Sensor PNP w/ quick disconnect Kit

* Requires sensor ready (-RM). Sensor kits include (2) sensors and (2) 5 meter cables.

MAGNETIC SENSORS * (Round track mounted)

RS-N - Magnetic Sensor NPN w/ quick disconnect
RS-P - Magnetic Sensor PNP w/ quick disconnect

* Requires sensor ready (-RM). Includes (1) sensor.

SENSOR CABLE

SENCAB-5 - Quick Disconnect PUR Cable 5M Length

SAMPLE ORDER: PH-31-D-RM

Ex) PH-31 (Flat Top Cap) With Dowel Holes and Sensor Ready

**CUSTOM DESIGNS ALWAYS AVAILABLE
PLEASE CONTACT US FOR INFORMATION**

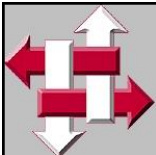

ADDITIONAL MOUNTING INFORMATION

The **DURA-GRIP PH-30** series offers an additional flat top for further flexibility to meet your design requirements.

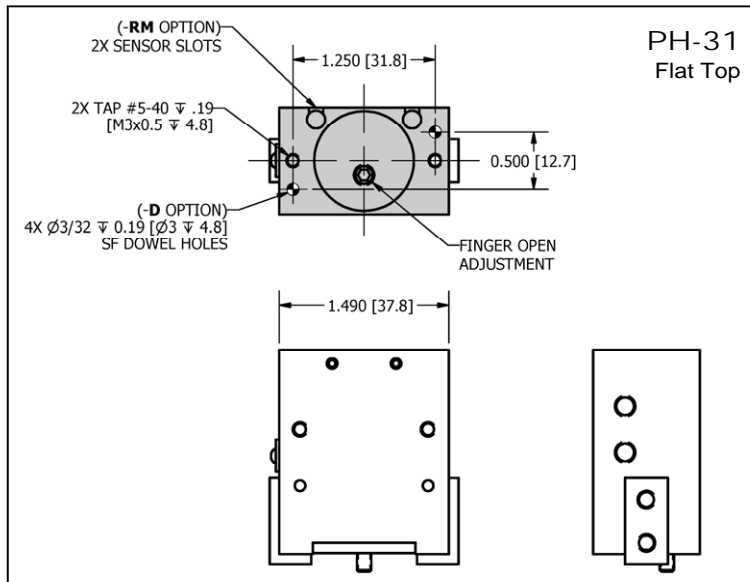

For further flexibility with the Dovetail, mount the PH-30 with custom dovetail tooling or use the DP-21 Universal receiver. Up to 2 PH-30 grippers can be mounted in the DP-21.

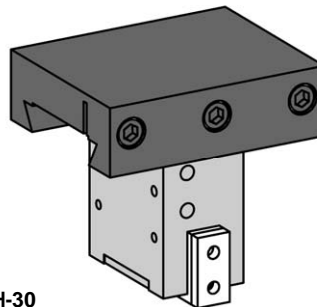

PH-30

See **DURA-GRIP ACCESSORIES** Page for the **DP-21** Universal Dovetail receiver Page 1-3.1

ADDITIONAL INFORMATION

GRIP FORCE

The maximum capacity of the gripper is a function of many variables and will change based on the shape of the part, surface finish, accelerations during transfer, the shape of the finger tooling, and air pressures. Use the Grip force calculated below *and* the application variables to determine the proper sizing of the gripper.

The Grip force - **F** is defined as the maximum force that can be applied to the fingers without moving. The force is analytically determined and will vary slightly with friction.

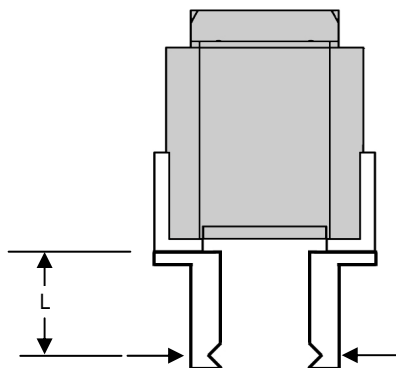

GRIP FACTOR G_F		PH-30	MPH-30
Standard Unit	EXTERNAL	0.214	13.76
	INTERNAL	0.125	8.08

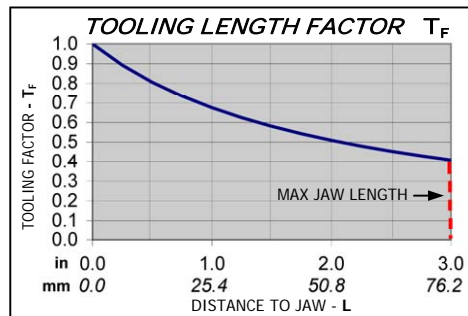

English **GRIP FORCE - F (lbf) = P_{AIR} (psi) x G_F x T_F**

Metric **GRIP FORCE - F (N) = P_{AIR} (bar) x G_F x T_F**

- P_{AIR} = Air Pressure
- G_F = Grip Factor (see chart)
- T_F = Tooling Factor (see graph)



It is recommended that finger tooling be designed to encompass the part as the grip force requirement is lower. If the grip cannot be performed by encompassing the part and a friction grip must be performed, always use a factor of safety of at least 4.

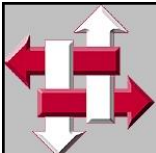

EXPLODED VIEW

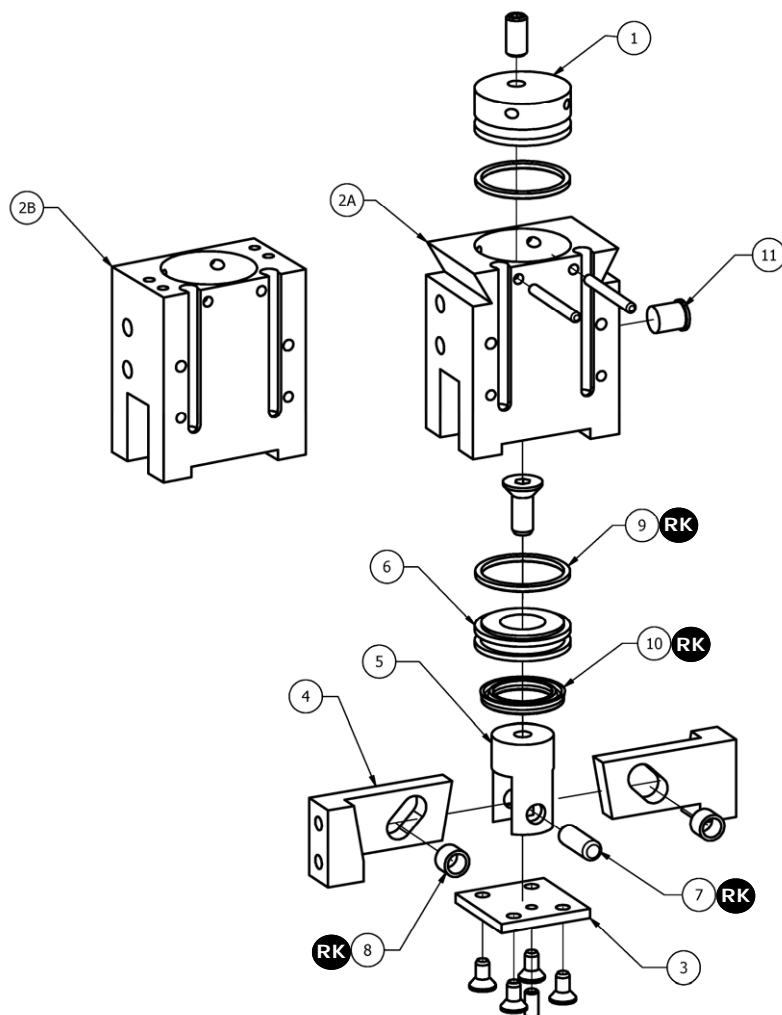

PARTS LIST

HOW TO ORDER PARTS

ITEM	REQ'D	NAME	PH-30	OPTIONS
1	1	Top Cap	PH-30-1	
2A	1	Dovetail Body	PH-30-2	-SFR ² -SFL ² -D ³ -RM ⁴
2B	1	Flat Body	PH-31-2	-SFR ² -SFL ² -D ³ -RM ⁴
3	1	Bottom Cap	PH-30-3	
4	2	Finger	PH-40-4	-SFR ² -SFL ²
5	1	Piston Shank	PH-40-5	
6	1	Piston	PH-40-6	-RM ⁵
7	1	Pin *	PH-40-7	
8	2	Roller *	PH-40-8	
9	2	Top Cap & Piston Seal *	ORG-018	-V ¹
10	1	Piston Shank Seal *	UCP-145	-V ¹
11	1	Oiler *	OIL-250	
RK	1	Repair Kit* #	PH-30-RK	-V ¹

METRIC PART NUMBER



OPTIONS

SAMPLE ORDER: PH-31-2

Ex) PH-31 (Flat Top) Body

OPTIONS (see product pages for information)

- 1 - V = Viton
- 2 - SFR / SFL = Stationary Finger Right or Left
- 3 - D = Dowel Pins
- 4 - RM = Magnetic Sensor Ready

NOTES

- * - Metric code not required
 - # - Repair Kits include req'd qty of parts marked with RK
- Note: Older models utilized an o-ring to seal the piston shank - This o-ring is also included in the repair kit.

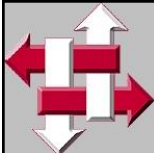

DIMENSIONAL DRAWING

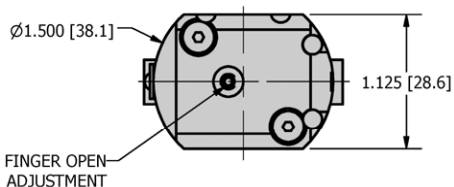

SPECIFICATIONS

	PH-40	MPH-40
Standard Grip Force @ 100 psi [7 bar] *	21 lbf	93 N
Standard Stroke	0.25 in	6.4 mm
Base Weight	0.31 lbs	0.14 kg
Unit Displacement (grip and release)	0.12 in ³	1.9 cm ³
Cylinder Bore Diameter	0.875 in	22.2 mm
Actuation Time (no load)	0.20 sec	

* Loading between lower jaw surface - zero tooling length

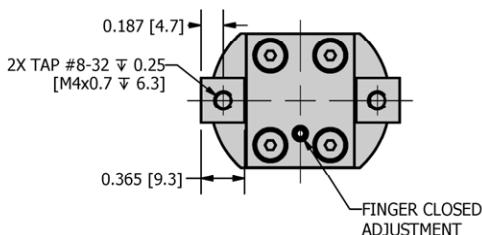
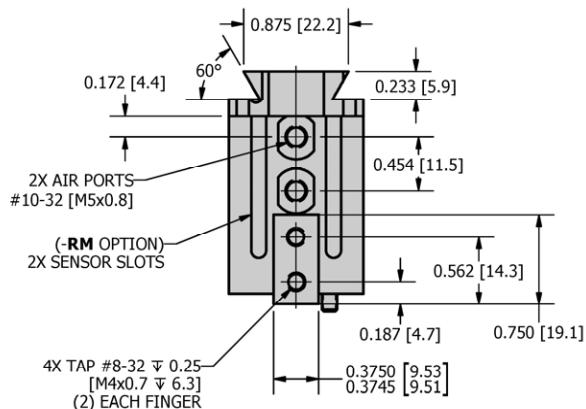
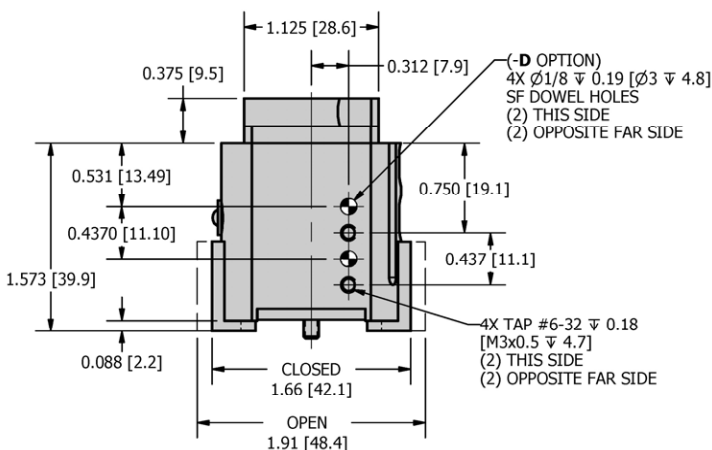

LOADING

	PH-40		MPH-40	
	Static	Dynamic	Static	Dynamic
Max Force F	100 lbf	20 lbf	444.5 N	88.9 N
Max Moment $M_{x,y,z}$	75 lbf-in	15 lbf-in	8.5 N-m	1.7 N-m

NOTE: Loading based on utilization of both fingers

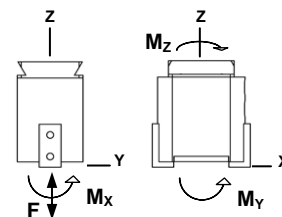

HOW TO ORDER : BASIC UNIT

ACCESSORIES (order separately)

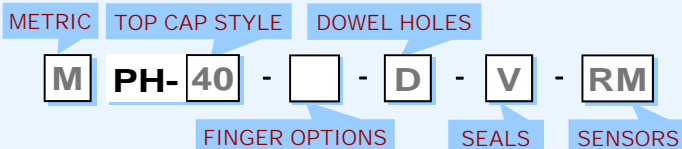

- METRIC** M
- TOP CAP** 40 - 60° Dovetail (shown above)
41 - Flat (see additional information section)
- FINGER OPTIONS** SFR - Stationary Right Finger
SFL - Stationary Left Finger (oiler side)
- DOWEL HOLES** D - Dowel Holes for positive location of unit
- SEALS** V - Viton (standard Buna - N)
- SENSORS** RM - Magnetic Sensor Ready
Includes Sensor slots and Piston Magnet . Sensors sold separately - see Magnetic Sensors

MAGNETIC SENSOR KITS * (Round track mounted)

- RSK-N - Magnetic Sensor NPN w/ quick disconnect Kit
- RSK-P - Magnetic Sensor PNP w/ quick disconnect Kit
- * Requires sensor ready (-RM). Sensor kits include (2) sensors and (2) 5 meter cables.

MAGNETIC SENSORS * (Round track mounted)

- RS-N - Magnetic Sensor NPN w/ quick disconnect
- RS-P - Magnetic Sensor PNP w/ quick disconnect
- * Requires sensor ready (-RM). Includes (1) sensor.

SENSOR CABLE

- SENCAB-5 - Quick Disconnect PUR Cable 5M Length

SAMPLE ORDER: PH-40-V

Ex) PH-40 (Dovetail Top Cap) With Viton Seals

**CUSTOM DESIGNS ALWAYS AVAILABLE
PLEASE CONTACT US FOR INFORMATION**

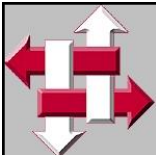

ADDITIONAL MOUNTING INFORMATION

The **DURA-GRIP PH-40** series offers an additional flat top for further flexibility to meet your design requirements.

For further flexibility with the Dovetail, mount the PH-40 with custom dovetail tooling or use the DP-11 Universal receiver.

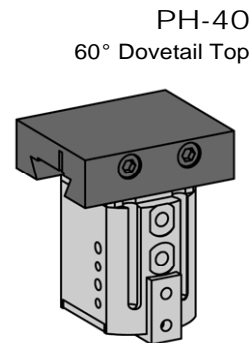
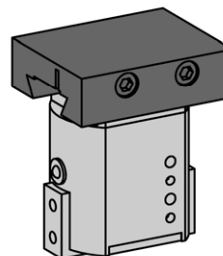
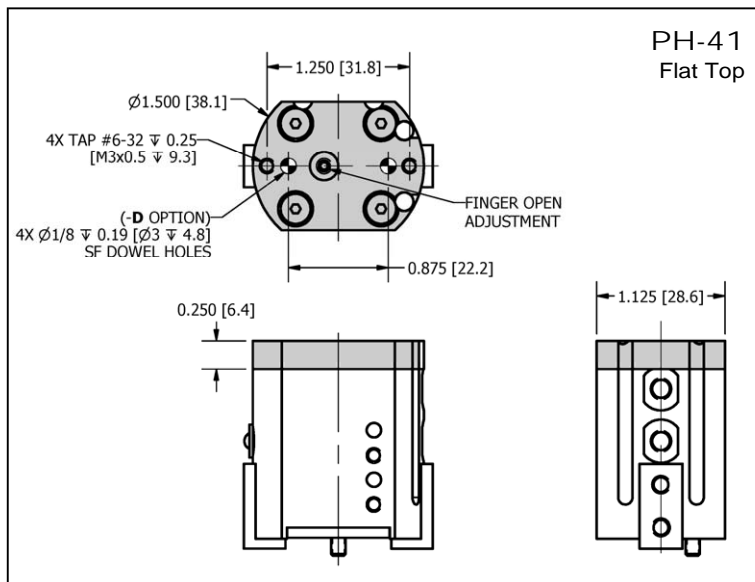

The Dovetail top cap on the PH-40 is designed to be rotated to allow either orientation shown

See **DURA-GRIP ACCESSORIES** Page for the **DP-11 Universal Dovetail receiver** Page **1-3.1**

ADDITIONAL INFORMATION

GRIP FORCE

The maximum capacity of the gripper is a function of many variables and will change based on the shape of the part, surface finish, accelerations during transfer, the shape of the finger tooling, and air pressures. Use the Grip force calculated below *and* the application variables to determine the proper sizing of the gripper.

The Grip force - **F** is defined as the maximum force that can be applied to the fingers without moving. The force is analytically determined and will vary slightly with friction.

GRIP FACTOR G_F		PH-40	MPH-40
Standard Unit	EXTERNAL	0.214	13.76
	INTERNAL	0.125	8.08

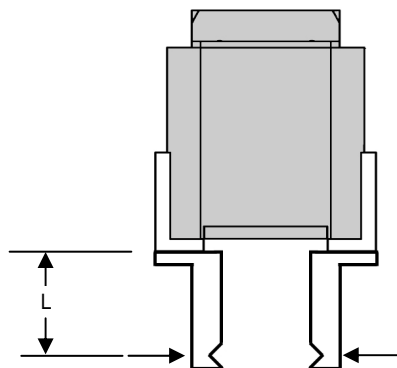
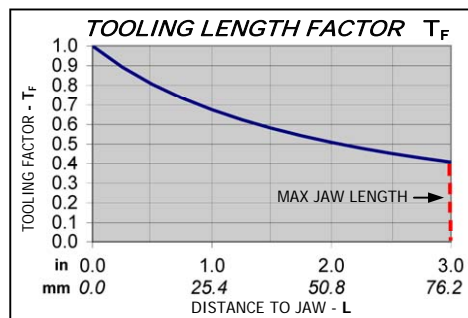

GRIP FORCE

English **GRIP FORCE - F (lbf) = P_{AIR} (psi) x G_F x T_F**

Metric **GRIP FORCE - F (N) = P_{AIR} (bar) x G_F x T_F**

- P_{AIR} = Air Pressure
- G_F = Grip Factor (see chart)
- T_F = Tooling Factor (see graph)



It is recommended that finger tooling be designed to encompass the part as the grip force requirement is lower. If the grip cannot be performed by encompassing the part and a friction grip must be performed, always use a factor of safety of at least 4.

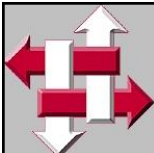

R&I
MANUFACTURING CO.

DURA-GRIP
PARALLEL GRIPPER

PH-50

DIMENSIONAL DRAWING

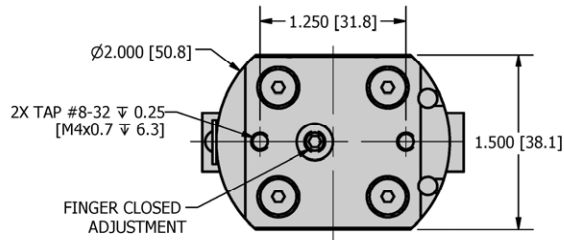

SPECIFICATIONS

	PH-50	MPH-50
Standard Grip Force @ 100 psi [7 bar] *	20 lbf	89 N
Standard Stroke	0.40 in	10.2 mm
Base Weight	0.81 lbs	0.37 kg
Unit Displacement (grip and release)	0.31 in ³	5.1 cm ³
Cylinder Bore Diameter	1.125 in	28.6 mm
Actuation Time (no load)		0.30 sec

* Loading between lower jaw surface - zero tooling length

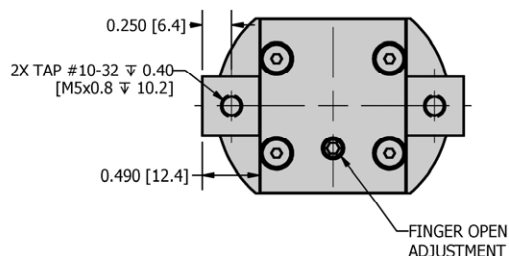
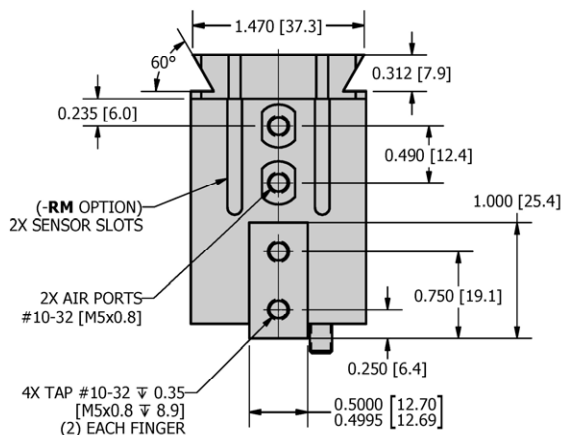
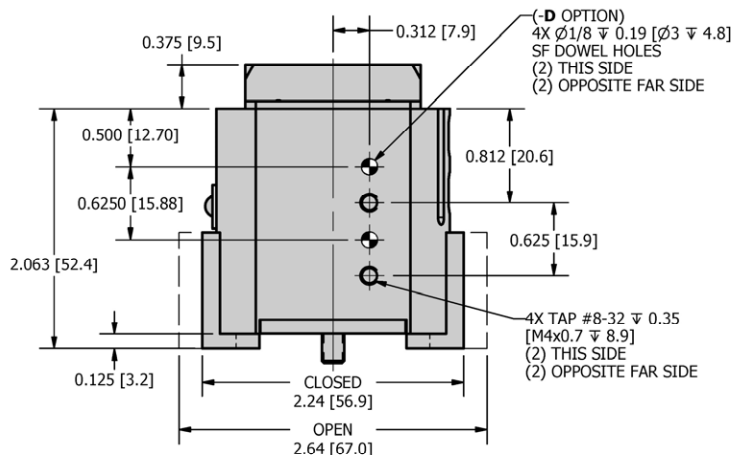

LOADING

	PH-50		MPH-50	
	Static	Dynamic	Static	Dynamic
Max Force F	200 lbf	25 lbf	889 N	111 N
Max Moment M_{x,y,z}	125 lbf-in	25 lbf-in	14.1 N-m	2.8 N-m

NOTE: Loading based on utilization of both fingers

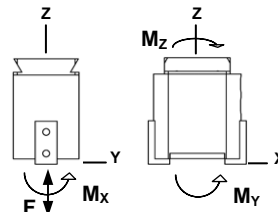

HOW TO ORDER : BASIC UNIT

ACCESSORIES (order separately)

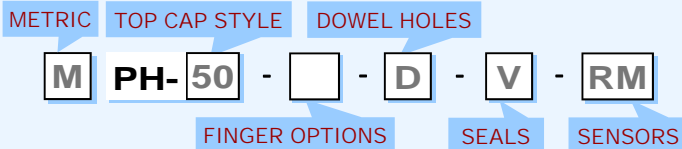

- METRIC** M
- TOP CAP** 50 - 60° Dovetail (shown above)
51 - Flat (see additional information section)
- FINGER OPTIONS** SFR - Stationary Right Finger
SFL - Stationary Left Finger (oiler side)
- DOWEL HOLES** D - Dowel Holes for positive location of unit
- SEALS** V - Viton (standard Buna - N)
- SENSORS** RM - Magnetic Sensor Ready
Includes Sensor slots and Piston Magnet . Sensors sold separately - see Magnetic Sensors

MAGNETIC SENSOR KITS * (Round track mounted)

- RSK-N - Magnetic Sensor NPN w/ quick disconnect Kit
- RSK-P - Magnetic Sensor PNP w/ quick disconnect Kit
- * Requires sensor ready (-RM). Sensor kits include (2) sensors and (2) 5 meter cables.

MAGNETIC SENSORS * (Round track mounted)

- RS-N - Magnetic Sensor NPN w/ quick disconnect
- RS-P - Magnetic Sensor PNP w/ quick disconnect
- * Requires sensor ready (-RM). Includes (1) sensor.

SENSOR CABLE

- SENCAB-5 - Quick Disconnect PUR Cable 5M Length

SAMPLE ORDER: PH-51-SFR

Ex) PH-51 (Flat Top Cap) With Stationary Right Finger

**CUSTOM DESIGNS ALWAYS AVAILABLE
PLEASE CONTACT US FOR INFORMATION**

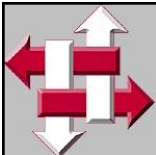

ADDITIONAL MOUNTING INFORMATION

The **DURA-GRIP PH-50** series offers an additional flat top for further flexibility to meet your design requirements.

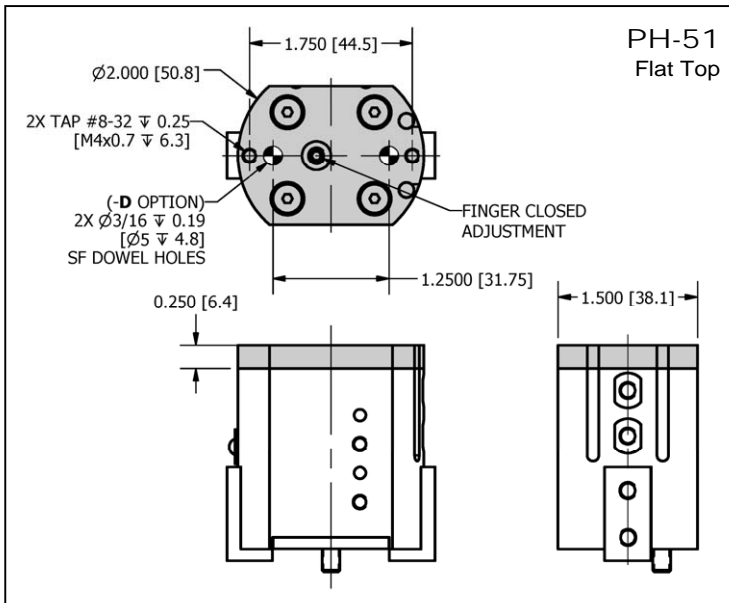

For further flexibility with the Dovetail, mount the PH-50 with custom dovetail tooling or use the DP-21 Universal receiver.

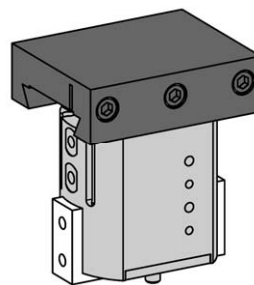

PH-50
60° Dovetail Top

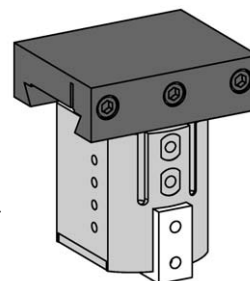

The Dovetail top cap on the PH-50 is designed to be rotated to allow either orientation shown

See **DURA-GRIP ACCESSORIES** Page for the **DP-21** Universal Dovetail receiver Page **1-3.1**

ADDITIONAL INFORMATION

GRIP FORCE

The maximum capacity of the gripper is a function of many variables and will change based on the shape of the part, surface finish, accelerations during transfer, the shape of the finger tooling, and air pressures. Use the Grip force calculated below *and* the application variables to determine the proper sizing of the gripper.

The Grip force - **F** is defined as the maximum force that can be applied to the fingers without moving. The force is analytically determined and will vary slightly with friction.

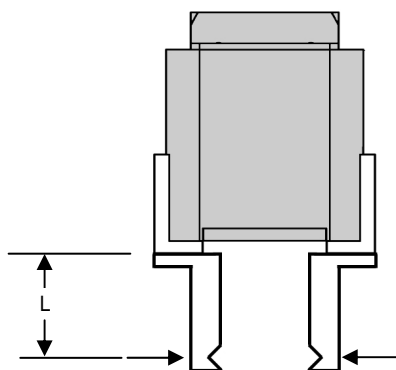

GRIP FORCE

GRIP FACTOR G_F		PH-50	MPH-50
Standard Unit	EXTERNAL	0.201	12.93
	INTERNAL	0.361	23.28

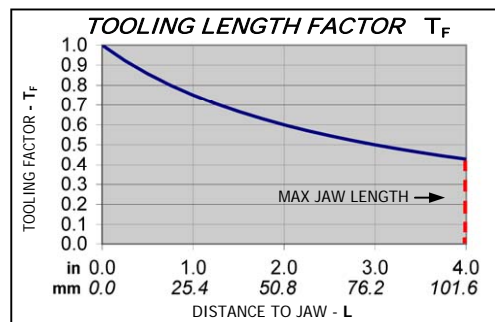

English **GRIP FORCE - F (lbf) = P_{AIR} (psi) x G_F x T_F**

Metric **GRIP FORCE - F (N) = P_{AIR} (bar) x G_F x T_F**

- P_{AIR} = Air Pressure
- G_F = Grip Factor (see chart)
- T_F = Tooling Factor (see graph)



It is recommended that finger tooling be designed to encompass the part as the grip force requirement is lower. If the grip cannot be performed by encompassing the part and a friction grip must be performed, always use a factor of safety of at least 4.

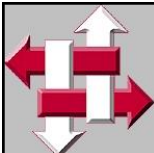

R&I
MANUFACTURING CO.

DURA-GRIP
PARALLEL GRIPPER

PH-60

DIMENSIONAL DRAWING

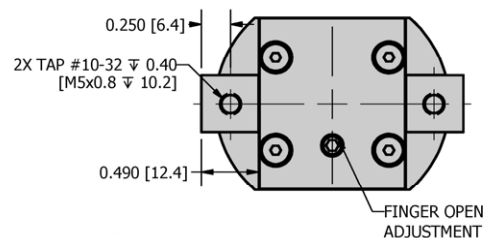
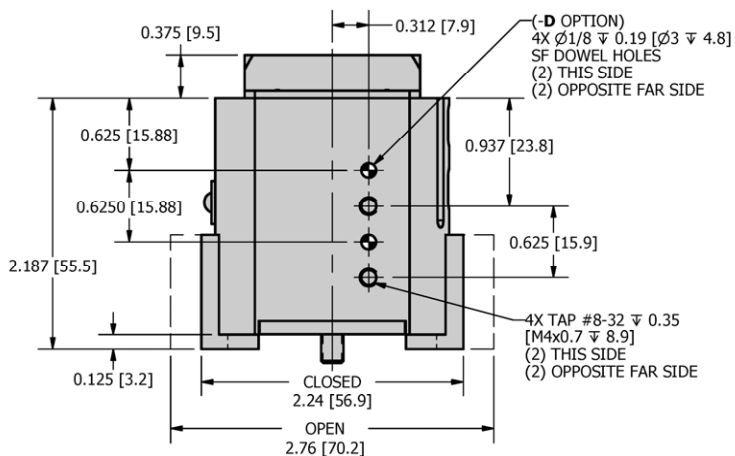
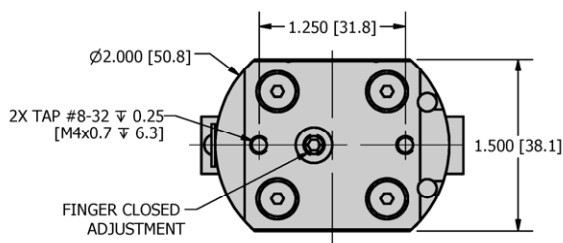

SPECIFICATIONS

	PH-60	MPH-60
Standard Grip Force @ 100 psi [7 bar] *	20 lbf	89 N
Standard Stroke	0.52 in	13.2 mm
Base Weight	0.88 lbs	0.40 kg
Unit Displacement (grip and release)	0.40 in ³	6.6 cm ³
Cylinder Bore Diameter	1.125 in	28.6 mm
Actuation Time (no load)	0.40 sec	

* Loading between lower jaw surface - zero tooling length

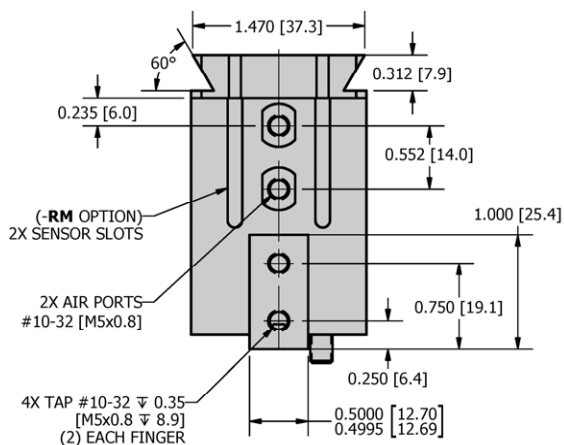

LOADING

	PH-60		MPH-60	
	Static	Dynamic	Static	Dynamic
Max Force F	200 lbf	25 lbf	889 N	111 N
Max Moment M _{x,y,z}	125 lbf-in	25 lbf-in	14.1 N-m	2.8 N-m

NOTE: Loading based on utilization of both fingers

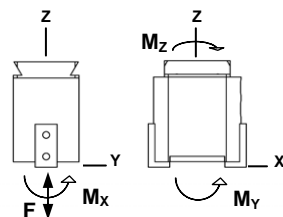

HOW TO ORDER : BASIC UNIT

ACCESSORIES (order separately)

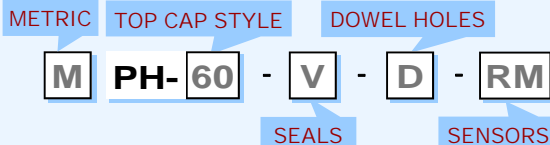

METRIC M

TOP CAP 60 - 60° Dovetail (shown above)
61 - Flat (see additional information section)

SEALS V - Viton (standard Buna - N)

DOWEL HOLES D - Dowel Holes for positive location of unit

SENSORS RM - Magnetic Sensor Ready
Includes Sensor slots and Piston Magnet . Sensors sold separately - see Magnetic Sensors

SAMPLE ORDER: PH-60-D-RM

Ex) PH-60 (Dovetail Top Cap) With Dowel Holes and Sensor Ready

MAGNETIC SENSOR KITS * (Round track mounted)

RSK-N - Magnetic Sensor NPN w/ quick disconnect Kit
RSK-P - Magnetic Sensor PNP w/ quick disconnect Kit

* Requires sensor ready (-RM). Sensor kits include (2) sensors and (2) 5 meter cables.

MAGNETIC SENSORS * (Round track mounted)

RS-N - Magnetic Sensor NPN w/ quick disconnect
RS-P - Magnetic Sensor PNP w/ quick disconnect

* Requires sensor ready (-RM). Includes (1) sensor.

SENSOR CABLE

SENCAB-5 - Quick Disconnect PUR Cable 5M Length

**CUSTOM DESIGNS ALWAYS AVAILABLE
PLEASE CONTACT US FOR INFORMATION**

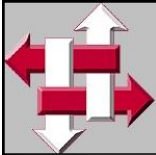

ADDITIONAL MOUNTING INFORMATION

The **DURA-GRIP PH-60** series offers an additional flat top for further flexibility to meet your design requirements.

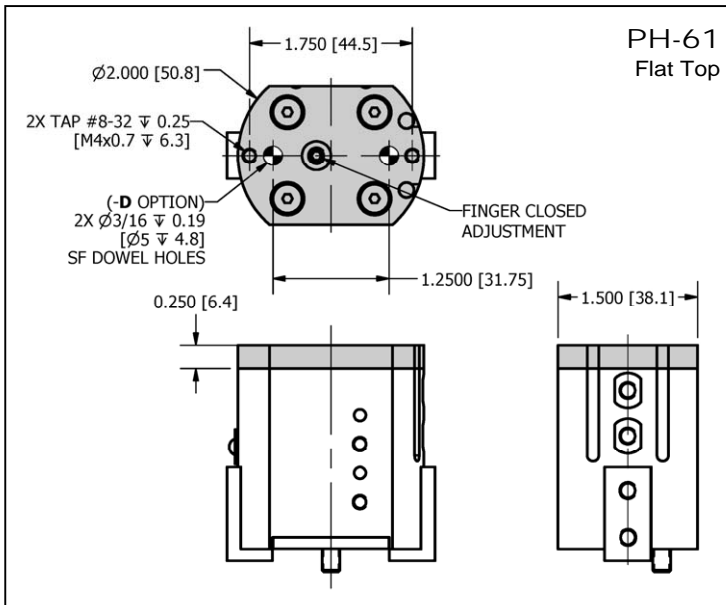

For further flexibility with the Dovetail, mount the PH-60 with custom dovetail tooling or use the DP-21 Universal receiver.

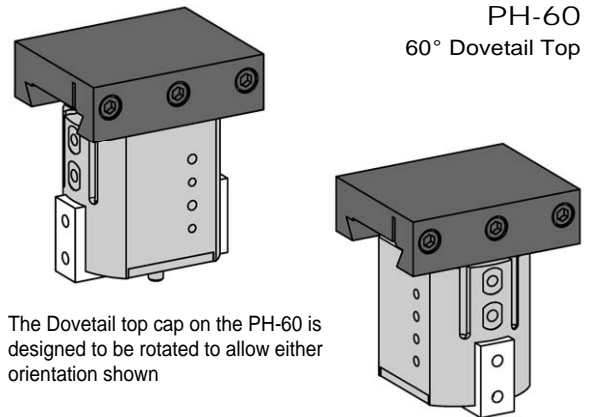

See **DURA-GRIP ACCESSORIES** Page for the **DP-21** Universal Dovetail receiver Page 1-3.1

ADDITIONAL INFORMATION

GRIP FORCE

The maximum capacity of the gripper is a function of many variables and will change based on the shape of the part, surface finish, accelerations during transfer, the shape of the finger tooling, and air pressures. Use the Grip force calculated below *and* the application variables to determine the proper sizing of the gripper.

The Grip force - **F** is defined as the maximum force that can be applied to the fingers without moving. The force is analytically determined and will vary slightly with friction.

GRIP FACTOR G_F		PH-60	MPH-60
Standard Unit	EXTERNAL	0.201	12.93
	INTERNAL	0.361	23.28

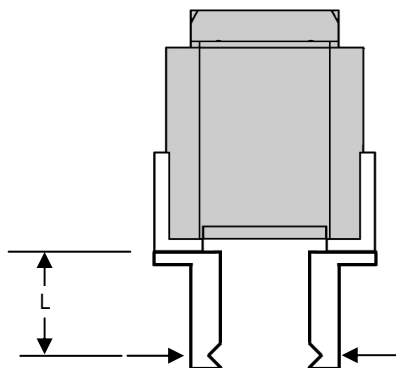
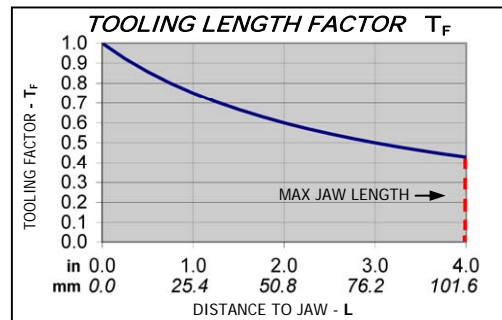

English **GRIP FORCE - F (lbf) = P_{AIR} (psi) x G_F x T_F**

Metric **GRIP FORCE - F (N) = P_{AIR} (bar) x G_F x T_F**

- P_{AIR}** = Air Pressure
- G_F** = Grip Factor (see chart)
- T_F** = Tooling Factor (see graph)



It is recommended that finger tooling be designed to encompass the part as the grip force requirement is lower. If the grip cannot be performed by encompassing the part and a friction grip must be performed, always use a factor of safety of at least 4.

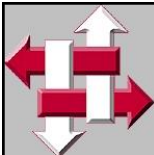

R&I
MANUFACTURING CO.

DURA-GRIP
PARALLEL GRIPPER

PH-70

DIMENSIONAL DRAWING

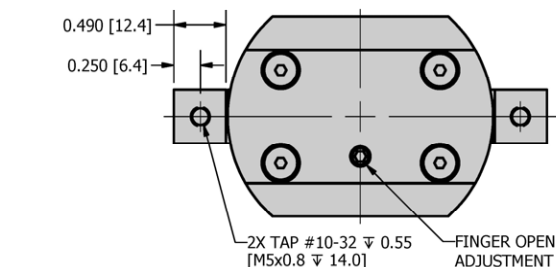
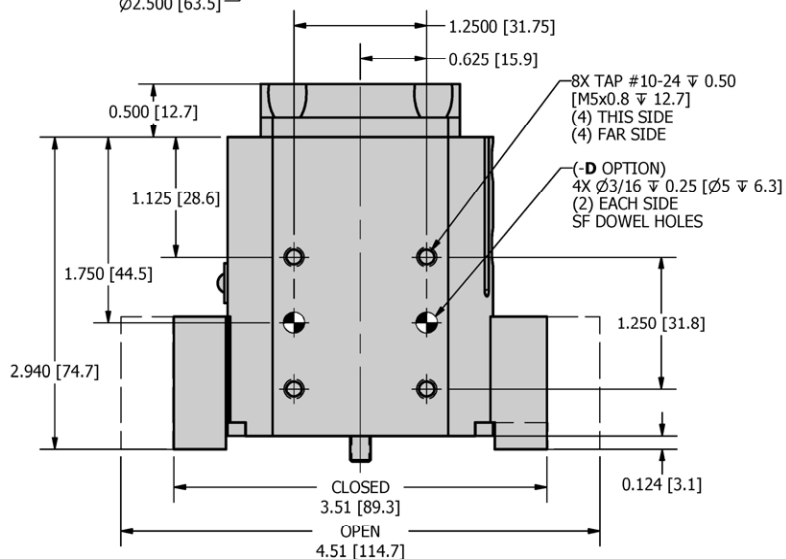
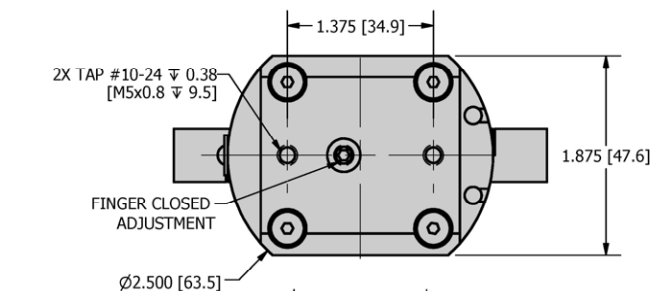

SPECIFICATIONS

	PH-70	MPH-70
Standard Grip Force @ 100 psi [7 bar] *	50 lbf	222 N
Standard Stroke	1.00 in	25.4 mm
Base Weight	1.75 lbs	0.79 kg
Unit Displacement (grip and release)	1.58 in ³	25.3 cm ³
Cylinder Bore Diameter	1.500 in	38.1 mm
Actuation Time (no load)	0.50 sec	

* Loading between lower jaw surface - zero tooling length

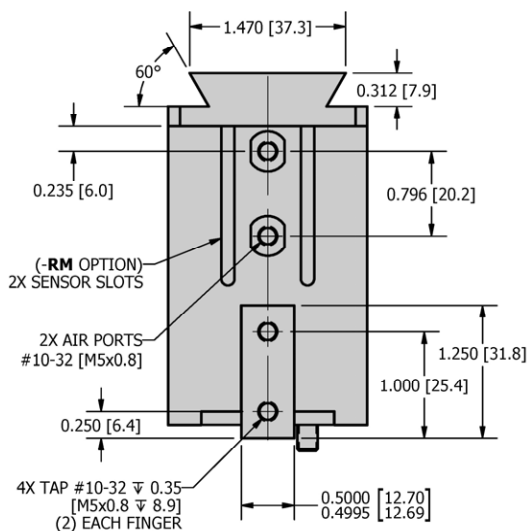

LOADING

	PH-70		MPH-70	
	Static	Dynamic	Static	Dynamic
Max Force F	250 lbf	35 lbf	1111 N	155.6 N
Max Moment M_{x,y,z}	200 lbf-in	40 lbf-in	22.6 N-m	4.5 N-m

NOTE: Loading based on utilization of both fingers

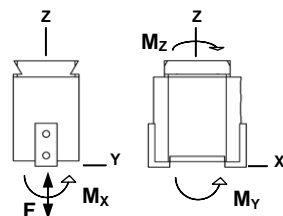

HOW TO ORDER : BASIC UNIT

ACCESSORIES (order separately)

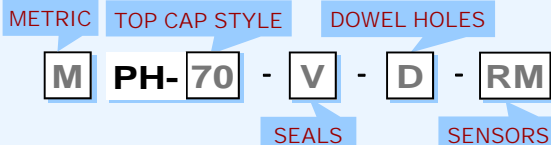

- METRIC** M
- TOP CAP** 70 - 60° Dovetail (shown above)
71 - Flat (see additional information section)
- SEALS** V - Viton (standard Buna - N)
- DOWEL HOLES** D - Dowel Holes for positive location of unit
- SENSORS** RM - Magnetic Sensor Ready
Includes Sensor slots and Piston Magnet. Sensors sold separately - see Magnetic Sensors

SAMPLE ORDER: PH-71-RM

Ex) PH-71 (Flat Top Cap) With Sensor Ready Option

MAGNETIC SENSOR KITS * (Round track mounted)

- RSK-N - Magnetic Sensor NPN w/ quick disconnect Kit
 - RSK-P - Magnetic Sensor PNP w/ quick disconnect Kit
- * Requires sensor ready (-RM). Sensor kits include (2) sensors and (2) 5 meter cables.

MAGNETIC SENSORS * (Round track mounted)

- RS-N - Magnetic Sensor NPN w/ quick disconnect
 - RS-P - Magnetic Sensor PNP w/ quick disconnect
- * Requires sensor ready (-RM). Includes (1) sensor.

SENSOR CABLE

- SENCAB-5 - Quick Disconnect PUR Cable 5M Length

**CUSTOM DESIGNS ALWAYS AVAILABLE
PLEASE CONTACT US FOR INFORMATION**

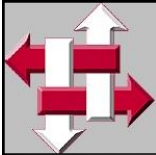

ADDITIONAL MOUNTING INFORMATION

The **DURA-GRIP PH-70** series offers an additional flat top for further flexibility to meet your design requirements.

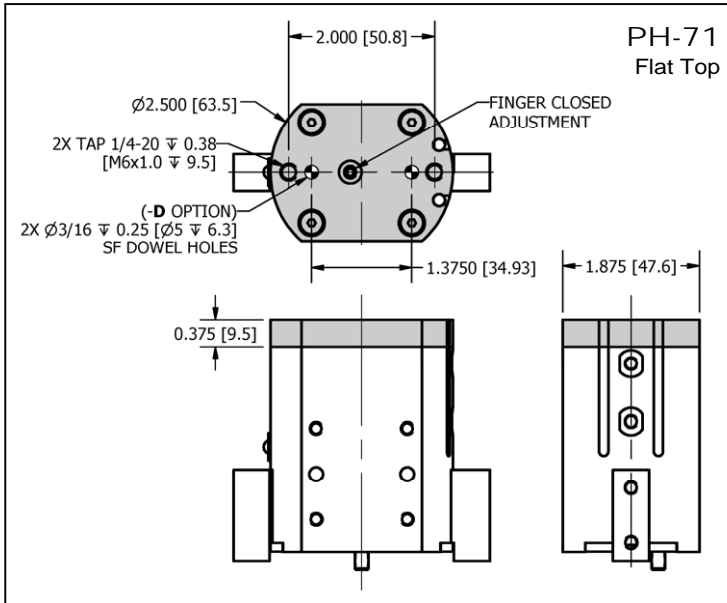

For further flexibility with the Dovetail, mount the PH-70 with custom dovetail tooling or use the DP-21 Universal receiver.

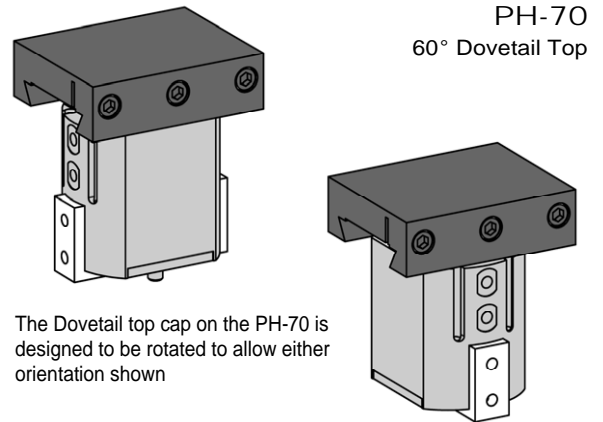

See **DURA-GRIP ACCESSORIES** Page for the **DP-21** Universal Dovetail receiver Page 1-3.1

ADDITIONAL INFORMATION

GRIP FORCE

The maximum capacity of the gripper is a function of many variables and will change based on the shape of the part, surface finish, accelerations during transfer, the shape of the finger tooling, and air pressures. Use the Grip force calculated below *and* the application variables to determine the proper sizing of the gripper.

The Grip force - **F** is defined as the maximum force that can be applied to the fingers without moving. The force is analytically determined and will vary slightly with friction.

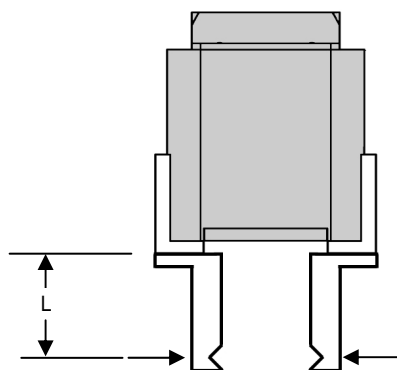

GRIP FACTOR G_F		PH-70	MPH-70
Standard Unit	EXTERNAL	0.498	32.06
	INTERNAL	0.664	42.76

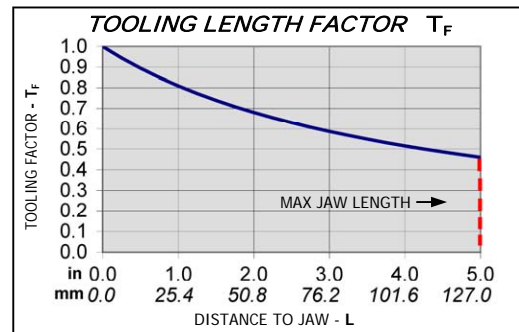

English **GRIP FORCE - F (lbf) = P_{AIR} (psi) x G_F x T_F**

Metric **GRIP FORCE - F (N) = P_{AIR} (bar) x G_F x T_F**

P_{AIR} = Air Pressure
 G_F = Grip Factor (see chart)
 T_F = Tooling Factor (see graph)



It is recommended that finger tooling be designed to encompass the part as the grip force requirement is lower. If the grip cannot be performed by encompassing the part and a friction grip must be performed, always use a factor of safety of at least 4.

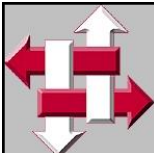

R&I
MANUFACTURING CO.

DURA-GRIP
PARALLEL GRIPPER

PH-SERIES

EXPLODED VIEW

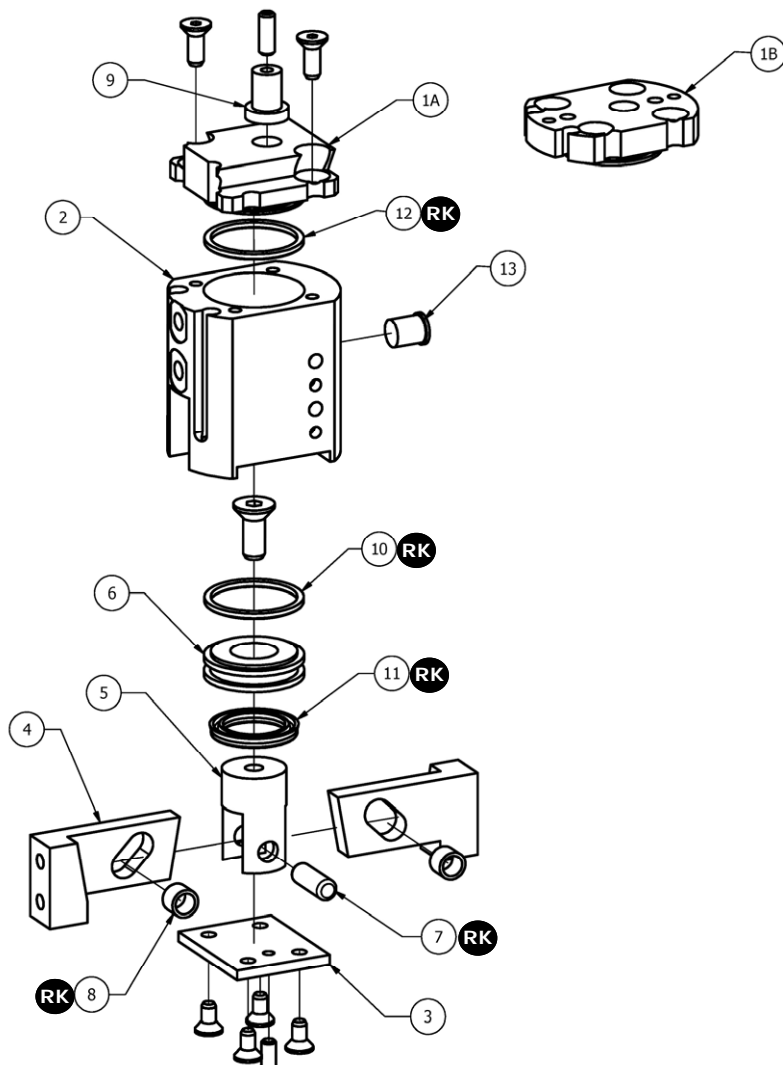

PARTS LIST

HOW TO ORDER PARTS

ITEM	REQ'D	NAME	PH-40	PH-50	PH-60	PH-70	OPTIONS
1A	1	Dovetail Top Cap	PH-40-1	PH-50-1	PH-60-1	PH-70-1	-RM ⁴
1B	1	Flat Top Cap	PH-41-1	PH-51-1	PH-61-1	PH-71-1	-D ³ -RM ⁴
2	1	Main Body	PH-40-2	PH-50-2	PH-60-2	PH-70-2	-SFR ² -SFL ² -D ³ -RM ⁴
3	1	Bottom Cap	PH-40-3	PH-50-3	PH-60-3	PH-70-3	
4	2	Finger	PH-40-4	PH-50-4	PH-60-4	PH-70-4	-SFR ² -SFL ²
5	1	Piston Shank	PH-40-5	PH-50-5	PH-60-5	PH-70-5	
6	1	Piston	PH-40-6	PH-50-6	PH-60-6	PH-70-6	-RM ⁴
7	1	Pin *	PH-40-7	PH-50-7	PH-60-7	PH-70-7	
8	2	Roller *	PH-40-8	PH-50-8	PH-60-8	PH-70-8	
9	1	Stop Bushing	PH-[40/41] ⁵ -9	PH-[50/51] ⁵ -9	PH-[60/61] ⁵ -9	PH-[70/71] ⁵ -9	
10	1	Piston Seal *	ORG-018	ORG-212	ORG-218	ORG-218	-V ¹
11	1	Piston Shank Seal *	UCP-145	UCP-145	ORG-016	ORG-016	-V ¹
12	1	Top Cap Seal *	ORG-018	ORG-022	ORG-028	ORG-028	
13	1	Oiler *	OIL-250	OIL-312	OIL-312	OIL-312	
RK	1	Repair Kit* #	PH-40-RK	PH-50-RK	PH-60-RK	PH-70-RK	-V ¹

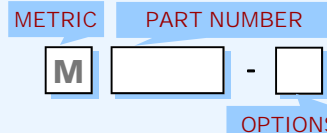

SAMPLE ORDER: PH-40-4
Ex) PH-40 Finger

OPTIONS (see product pages for information)

- 1 - V = Viton
- 2 - SFR / SFL = Stationary Finger Right or Left
- 3 - D = Dowel Holes
- 4 - RM = Magnetic Sensor Ready
- 5 - TOP CAP STYLE

NOTES

- * - Metric code not required
- # - Repair Kits include req'd qty of parts marked with RK
- Note: Older PH-40 models utilized an o-ring to seal the piston shank - This o-ring is also included in the repair kit.

FOR MORE INFORMATION CALL US AT 1-800-588-0174 OR 860-589-6364 FAX: 860-589-6235

VISIT US AT www.RIMFG.com



LP-SERIES - LOW PROFILE



DURA-GRIP LP Series of Part Placement Devices is designed to provide a low cost gripping unit for use in applications where the minimum overall height is critical. The LP series provides an exceptional amount of finger stroke when compared to other units of similar height. These air operated units grip parts internally or externally offering the designer a wide latitude in finger tooling arrangements. All units are shipped completely assembled ready for mounting and attaching tooling.

QUALITY CONSTRUCTION

DURA-GRIP LP Series is ruggedly constructed with a minimum of moving parts. The high strength aluminum body is hard coated, and the fingers are hardened steel for excellent durability. The fingers are fully supported through their entire stroke providing high moment capacity and longer finger lengths.

MOUNTING INFORMATION

DURA-GRIP LP Series can be mounted and operated in any plane and orientation. Standard mounting holes and precision dowels holes are provided on top and back of unit for easy mounting.

ADDITIONAL FEATURES

DURA-GRIP LP Series is sensor ready for use with magnetic sensors to sense open and closed positions. Many finger options are available including synchronous, non-synchronous operations, and stationary fingers.

Use the LP Series of Parallel Grippers wherever you need low-profile, durable and precise part placement.

SPECS

BORE DIA - 0.625" [15.9mm]
STROKE - 0.750" [19.1mm]

LP-75

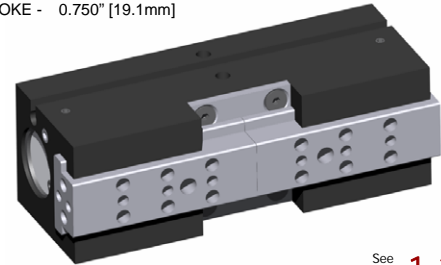

See Page **1-2.22**

SPECS

BORE DIA - 0.625" [15.9mm]
STROKE - 1.000" [25.4mm]

LP-100

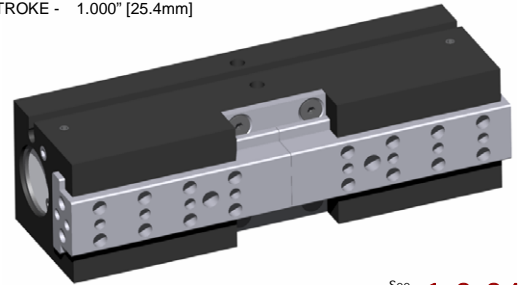

See Page **1-2.24**

TECHNICAL SPECIFICATION

Pneumatic Specifications

	ENGLISH	METRIC
Pressure Range	40-100 psi	3-7 bar
Cylinder Type	2 Double Acting	
Dynamic Seals	Buna-N	
Required Valves	4-way, 2 position	

Temperature Range

Buna-N Seals (standard)	-30 to 180 F	-35 to 80 C
Viton Seals (-V option)	-20 to 300 F	-30 to 150 C

OPERATING PRINCIPLES

- Air pressure drives two double acting pistons which are directly connected to gripper fingers.
- Fingers are internally linked to provide synchronized motion.
- Precision t-slot guides fingers accurately and provides support through entire stroke
- Gripper is capable of external and internal gripping

OPTIONAL OPERATIONS

- *SYNCHRONOUS & NON-SYNCHRONOUS*
- *STATIONARY FINGERS*

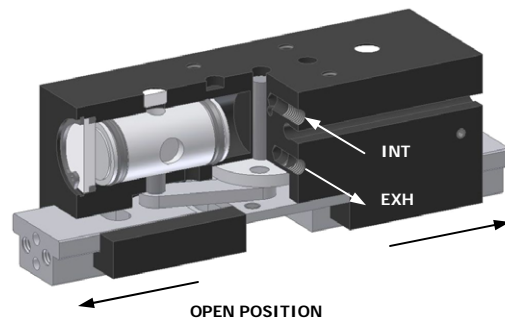
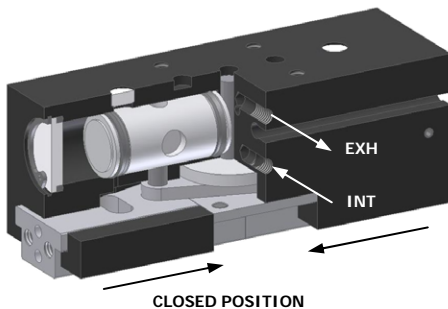

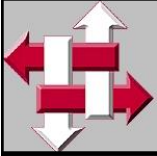

PRODUCT FEATURES

- Aircraft Grade Aluminum
Hard Coat Anodize
- Simple and Highly Durable
Time tested, field approved design
- Low Profile
Longer stroke with minimum height

Rugged Design
Extremely durable for high cycle life. Oversized components, hardened steel fingers, and Hard Coat anodized aluminum body.

Fully Rebuildable
Fully field serviceable with factory repair kits

Sensors Ready
Standard piston magnets for use with our RS style sensors. *Sensors sold separately*

U-cup Seals
High cycle life. Buna-N standard with optional Viton (-V Option)

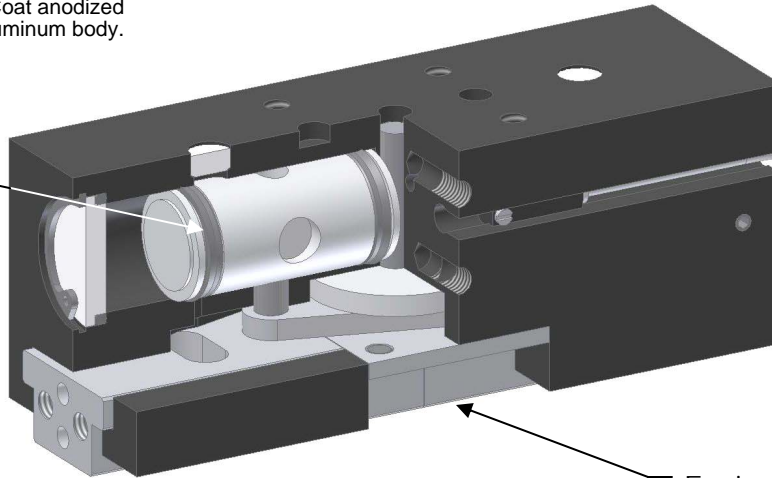

Compact Design
Low profile and long stroke for height limited applications

Engineered Surface Coating
Anti-Friction and Anti-Wear on fingers

Multiple Finger Options
Standard synchronized motion with optional non-synchronous operation, and stationary fingers

Precision Mounting Features
Dowels holes located on body and fingers for precision location of unit and tooling

DESIGNED - MANUFACTURED - ASSEMBLED IN THE USA



MOUNTING INFORMATION

Mounts and operates in any orientation

MAIN BODY

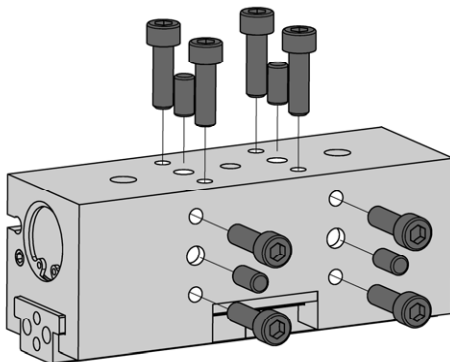

Mount up to Main body with Tapped holes located on back, and top of unit.

Use standard precision Dowel holes on the top and back side of the unit for positive location.

TOOLING

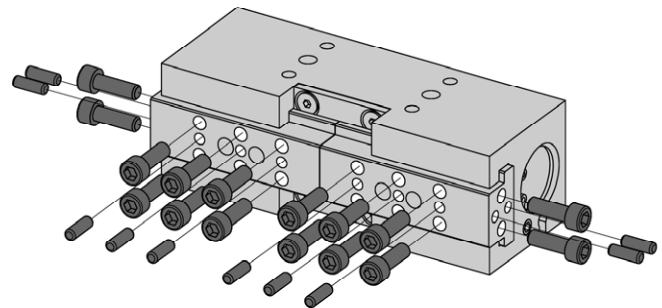

Mount tooling to fingers using Tapped holes located on the bottom and sides of fingers

Key tooling to precision ground fingers or utilize dowel holes for positive location.

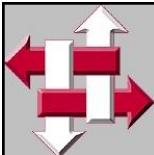

R&I
MANUFACTURING CO.

DURA-GRIP
PARALLEL GRIPPER



LP-75

DIMENSIONAL DRAWING

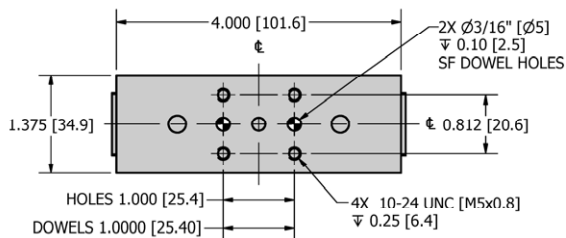

SPECIFICATIONS

	LP-75	MLP-75
Standard Grip Force @ 100 psi [7 bar] *	25 lbf	111 N
Standard Stroke	0.75 in	19.1 mm
Base Weight	0.9 lbs	0.41 kg
Unit Displacement (grip and release)	0.46 in ³	7.5 cm ³
Cylinder Bore Diameter	0.625 in	15.9 mm
Actuation Time (no load)	0.20 sec	

* Loading between lower jaw surface - zero tooling length

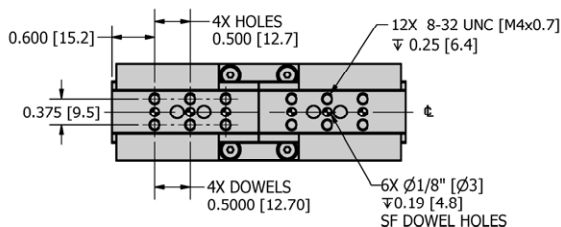
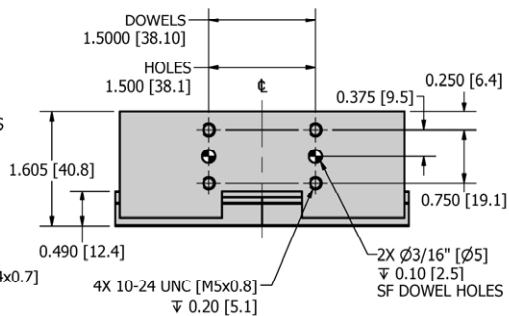
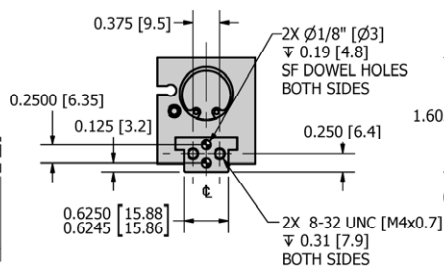
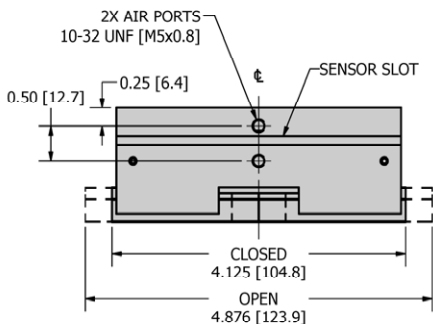

LOADING

	LP-75		MLP-75	
	Static	Dynamic	Static	Dynamic
Max Tension T	225 lbf	30 lbf	1000 N	133 N
Max Compression C	450 lbf	30 lbf	2000 N	133 N
Max Moment M_{x,y,z}	215 lbf-in	35 lbf-in	24 N-m	4 N-m

NOTE: Loading based on utilization of both fingers

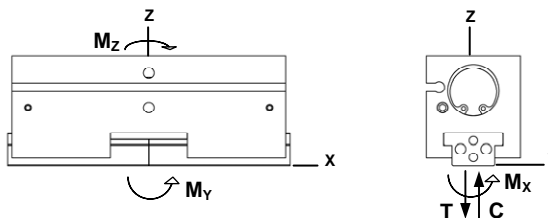

HOW TO ORDER : BASIC UNIT

ACCESSORIES (order separately)

METRIC

FINGER OPTIONS

M **LP-75** - - **V**

SEALS

METRIC M

FINGER OPTIONS SFR - Stationary Right Finger
SFL - Stationary Left Finger
NS - Non-synchronous finger motion

SEALS V - Viton (standard Buna - N)

SAMPLE ORDER: LP-75-NS

Ex) LP-75 With Non-synchronous finger motion

MAGNETIC SENSOR KITS * (Round track mounted)

RSK-N - Magnetic Sensor NPN w/ quick disconnect Kit
RSK-P - Magnetic Sensor PNP w/ quick disconnect Kit

* Sensor kits include (2) sensors and (2) 5 meter cables.

MAGNETIC SENSORS * (Round track mounted)

RS-N - Magnetic Sensor NPN w/ quick disconnect
RS-P - Magnetic Sensor PNP w/ quick disconnect

* Includes (1) sensor.

SENSOR CABLE

SENCAB-5 - Quick Disconnect PUR Cable 5M Length

**CUSTOM DESIGNS ALWAYS AVAILABLE
PLEASE CONTACT US FOR INFORMATION**

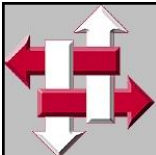

OPTIONS INFORMATION

STATIONARY FINGER (-SFL / -SFR)

The LP series can be ordered with a stationary left finger (-SFL) or a stationary right finger (-SFR) for use when gripping parts that need to be referenced to a specific edge or surface. The stationary jaw will reference the edge or surface and the moving jaw can compensate for any change in material size. (-SFL Shown)

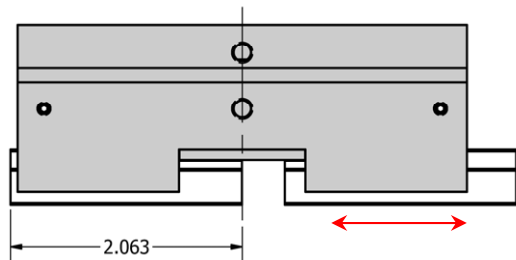

NON-SYNCHRONOUS OPERATION (-NS)

The LP series can be ordered with Non-Synchronous finger motion to permit the gripping of parts off centerline of the unit. Use this option whenever there is a miss-match between part centerline and gripper centerline

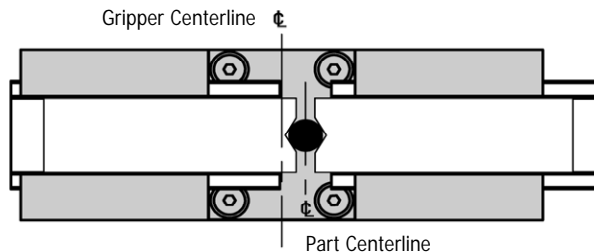

ADDITIONAL INFORMATION

GRIP FORCE

The maximum capacity of the gripper is a function of many variables and will change based on the shape of the part, surface finish, accelerations during transfer, the shape of the finger tooling, and air pressures. Use the Grip force calculated below and the application variables to determine the proper sizing of the gripper.

The Grip force - **F** is defined as the maximum force that can be applied to the fingers without moving. The force is analytically determined and will vary slightly with friction.

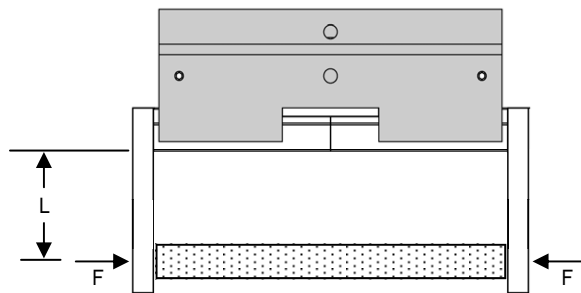

GRIP FACTOR G_F		LP-75	MLP-75
Standard Unit	EXTERNAL	0.254	16.38
	INTERNAL	0.254	16.38

English **GRIP FORCE - F (lbf) = P_{AIR} (psi) x G_F x T_F**

Metric **GRIP FORCE - F (N) = P_{AIR} (bar) x G_F x T_F**

P_{AIR} = Air Pressure
 G_F = Grip Factor (see chart)
 T_F = Tooling Factor (see graph)

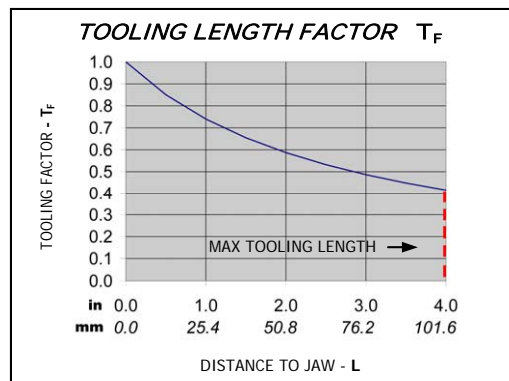

It is recommended that finger tooling be designed to encompass the part as the grip force requirement is lower. If the grip cannot be performed by encompassing the part and a friction grip must be performed, always use a factor of safety of at least 4.

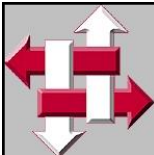

R&I
MANUFACTURING CO.

DURA-GRIP
PARALLEL GRIPPER



LP-100



DIMENSIONAL DRAWING

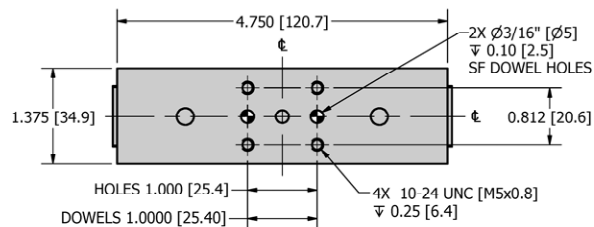

SPECIFICATIONS

	LP-100	MLP-100
Standard Grip Force @ 100 psi [7 bar] *	25 lbf	111 N
Standard Stroke	1.00 in	25.4 mm
Base Weight	1.1 lbs	0.5 kg
Unit Displacement (grip and release)	0.62 in ³	10.1 cm ³
Cylinder Bore Diameter	0.625 in	15.9 mm
Actuation Time (no load)	0.25 sec	

* Loading between lower jaw surface - zero tooling length

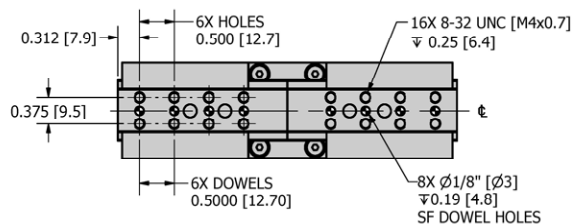
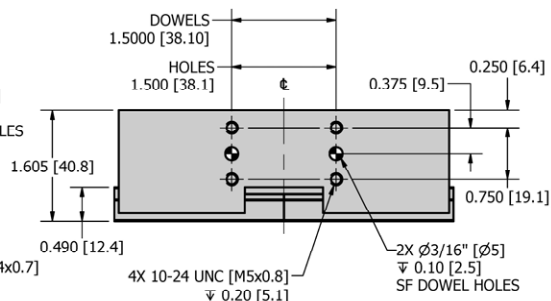
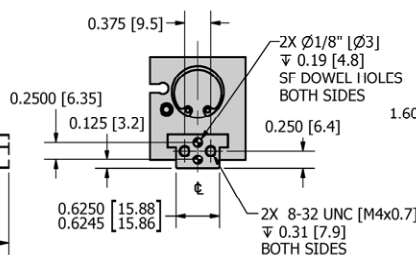
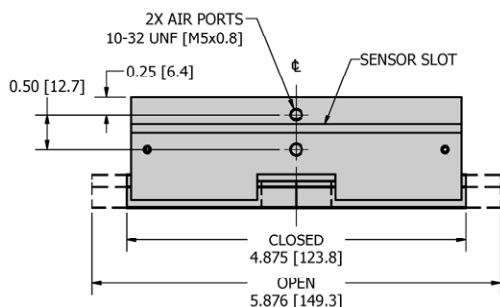

LOADING

	LP-100		MLP-100	
	Static	Dynamic	Static	Dynamic
Max Tension T	250 lbf	35 lbf	1111 N	156 N
Max Compression C	475 lbf	35 lbf	2111 N	156 N
Max Moment M_{x,y,z}	235 lbf-in	40 lbf-in	27 N-m	4.5 N-m

NOTE: Loading based on utilization of both fingers

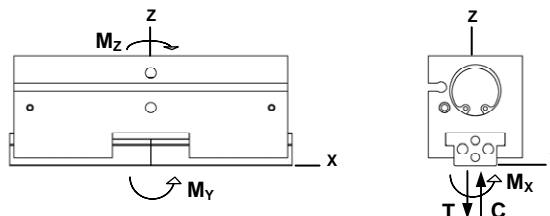

HOW TO ORDER : BASIC UNIT

ACCESSORIES (order separately)

METRIC

FINGER OPTIONS



SEALS

METRIC M

FINGER OPTIONS SFR - Stationary Right Finger
SFL - Stationary Left Finger
NS - Non-synchronous finger motion

SEALS V - Viton (standard Buna - N)

SAMPLE ORDER: MLP-100-V

Ex) Metric LP-100 With Viton Seals

MAGNETIC SENSOR KITS * (Round track mounted)

RSK-N - Magnetic Sensor NPN w/ quick disconnect Kit
RSK-P - Magnetic Sensor PNP w/ quick disconnect Kit

* Sensor kits include (2) sensors and (2) 5 meter cables.

MAGNETIC SENSORS * (Round track mounted)

RS-N - Magnetic Sensor NPN w/ quick disconnect
RS-P - Magnetic Sensor PNP w/ quick disconnect

* Includes (1) sensor.

SENSOR CABLE

SENCAB-5 - Quick Disconnect PUR Cable 5M Length

**CUSTOM DESIGNS ALWAYS AVAILABLE
PLEASE CONTACT US FOR INFORMATION**

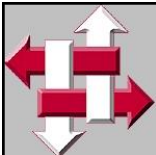

OPTIONS INFORMATION

STATIONARY FINGER (-SFL / -SFR)

The LP series can be ordered with a stationary left finger (-SFL) or a stationary right finger (-SFR) for use when gripping parts that need to be referenced to a specific edge or surface. The stationary jaw will reference the edge or surface and the moving jaw can compensate for any change in material size. (-SFL Shown)

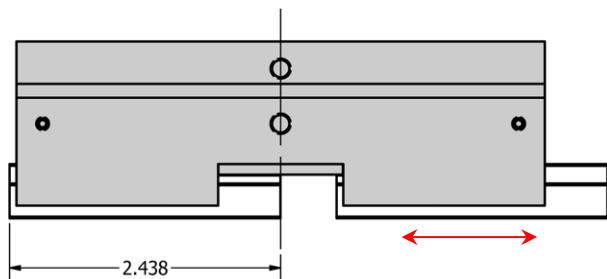

NON-SYNCHRONOUS OPERATION (-NS)

The LP series can be ordered with Non-Synchronous finger motion to permit the gripping of parts off centerline of the unit. Use this option whenever there is a miss-match between part centerline and gripper centerline

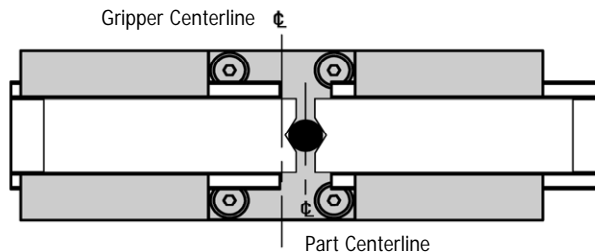

ADDITIONAL INFORMATION

GRIP FORCE

The maximum capacity of the gripper is a function of many variables and will change based on the shape of the part, surface finish, accelerations during transfer, the shape of the finger tooling, and air pressures. Use the Grip force calculated below and the application variables to determine the proper sizing of the gripper.

The Grip force - **F** is defined as the maximum force that can be applied to the fingers without moving. The force is analytically determined and will vary slightly with friction.

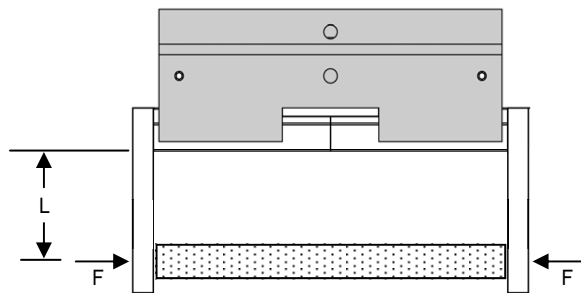

GRIP FACTOR G_F		LP-100	MLP-100
Standard Unit	EXTERNAL	0.263	16.94
	INTERNAL	0.263	16.94

English **GRIP FORCE - F (lbf) = P_{AIR} (psi) x G_F x T_F**

Metric **GRIP FORCE - F (N) = P_{AIR} (bar) x G_F x T_F**

- P_{AIR} = Air Pressure
- G_F = Grip Factor (see chart)
- T_F = Tooling Factor (see graph)

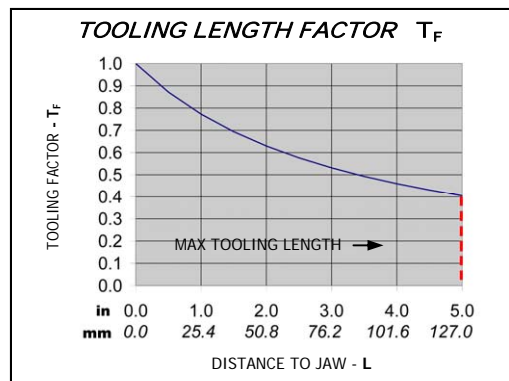

It is recommended that finger tooling be designed to encompass the part as the grip force requirement is lower. If the grip cannot be performed by encompassing the part and a friction grip must be performed, always use a factor of safety of at least 4.



R&I
MANUFACTURING CO.

DURA-GRIP
PARALLEL GRIPPER

LP-SERIES

EXPLODED VIEW

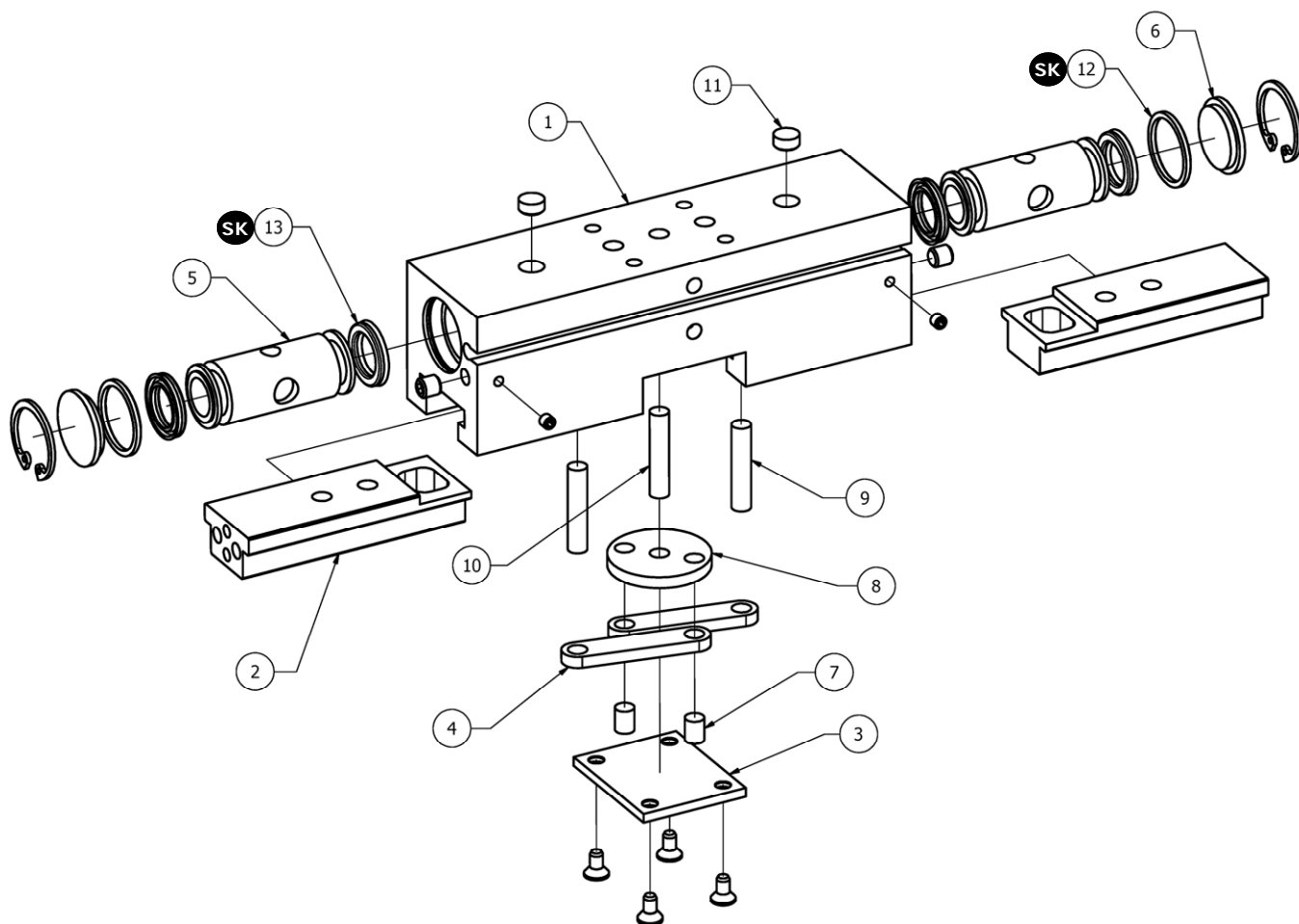

PARTS LIST

HOW TO ORDER PARTS

ITEM	REQ'D	NAME	LP-75	LP-100	OPTIONS
1	1	Body	LP-75-1	LP-100-1	
2	2	Finger	LP-75-2	LP-100-2	
3	1	Bottom Cover	LP-100-3		
4	2	Connecting Rod *	LP-75-4	LP-100-4	
5	2	Piston *	LP-75-5	LP-100-5	-SFR ² -SFL ²
6	2	Cylinder Cap *	LP-100-6		
7	2	Link Pin *	LP-100-7		
8	1	Link *	LP-100-8		
9	2	Finger Pin *	LP-100-9		-SFR ² -SFL ²
10	1	Pivot Pin *	LP-100-10		
11	2	Plug *	LP-100-11		
12	2	Cylinder Cap Seal *	ORG-016		-V ¹
13	4	Piston Seal *	UCP-130		-V ¹
SK	1	Seal Kit **	LP-SK		-V ¹

Consult Factory if option or part is not listed

METRIC PART NUMBER



OPTIONS

SAMPLE ORDER: LP-75-2

Ex) LP-75 Finger

OPTIONS (see product pages for information)

¹ - V = Viton

² - SFR / SFL = Stationary Finger Right or Left

NOTES

* - Metric code not required

- Seal Kits include req'd qty of parts marked with SK



PH-20 - STACK PACK

DURA-GRIP PH-20 Part Placement Device is designed to provide a low cost, thin profile, stackable gripping unit for use on transfer mechanisms. The thin profile allows close center distance mounting for multiple head stacking as required in racking/deracking, palletizing/depalletizing or other similar applications. This air operated unit grips parts internally or externally offering the designer a wide latitude in finger tooling arrangements. All units are shipped completely assembled, ready for mounting and attaching tooling.

QUALITY CONSTRUCTION

DURA-GRIP PH-20 is ruggedly constructed with a minimum of moving parts and utilizes the same field proven mechanism found in our other parallel grippers. The body is anodized high strength aluminum, fingers are hardened tool steel. Both finger opening and closing position can be adjusted on the unit. The unit can be mounted in any plane with standard mounting holes or with integral dovetail.

Use the PH-20 Parallel Gripper in some of the following applications or wherever you need durable and precise part placement with a thin profile

- Racking / Deracking operations
- Palletizing / Depalletizing operations
- Small workpiece center to center distance

STACKABLE HEAD

PH-20

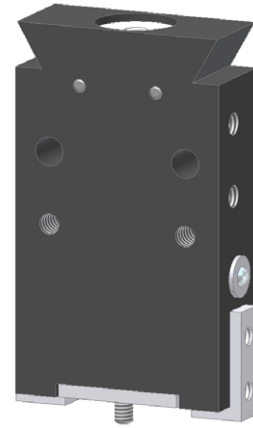

TECHNICAL SPECIFICATION

Pneumatic Specifications	ENGLISH	METRIC
Pressure Range	40-100 psi	3-7 bar
Cylinder Type	Double Acting	
Dynamic Seals	Buna-N	
Required Valves	4-way, 2 position	
Temperature Range		
Buna-N Seals (standard)	-30 to 180 F	-35 to 80 C
Viton Seals (-V option)	-20 to 300 F	-30 to 150 C

OPERATING PRINCIPLES - STANDARD UNIT

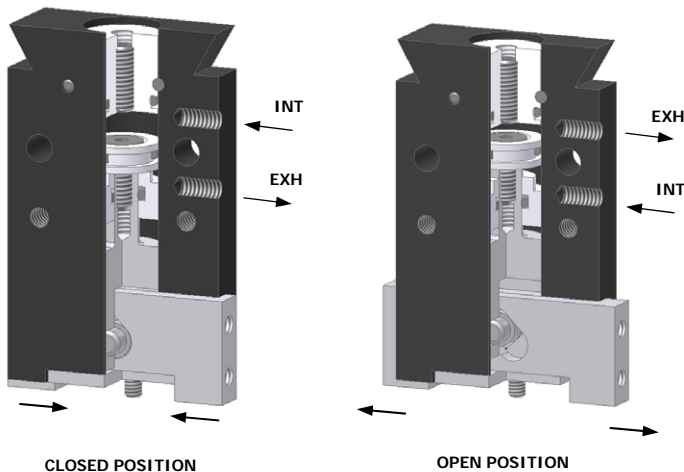

- Air pressure drives double acting piston.
- Piston drives fingers through precision slots producing synchronized parallel motion.
- Gripper is capable of external and internal gripping

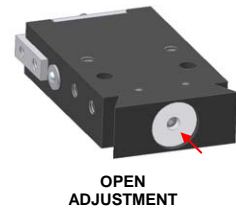
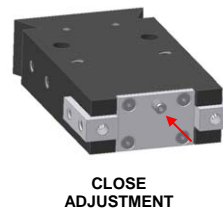

Finger closed and open position can be adjusted with set screws located in the bottom and top cap of the unit.

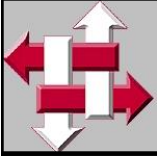

PRODUCT FEATURES

- Aircraft Grade Aluminum
2024 with black anodize
- Simple and Highly Durable
Time tested, field approved design
- High Grip Force
High gripping force-to-weight ratio

Stackable Design

Extremely Compact Design

Rugged One Piece Body
Extremely durable for high cycle life

Precision Components
Precision ground and hardened fingers
for accurate tooling location

Adjustable Finger Stops
On both open and closed positions. Provides
precise and accurate finger stroke control

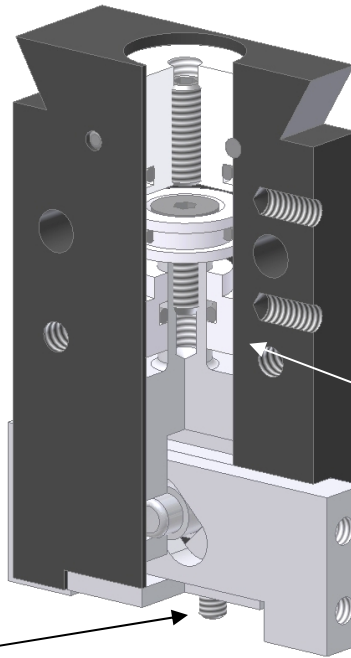

Fully Rebuildable
Fully field serviceable with
factory repair kits

Multiple Mounting Features
Tapped and Clearance holes for mounting
the unit and additional stripper tooling.
Integral Dovetail mounting on body

O-ring Seals
High cycle life. Buna-N standard with
optional Viton (-V Option)

Engineered Surface Coating
Anti-Friction and Anti-Wear on fingers

DESIGNED - MANUFACTURED - ASSEMBLED IN THE USA

MOUNTING INFORMATION

Mounts and operates in any orientation

MAIN BODY

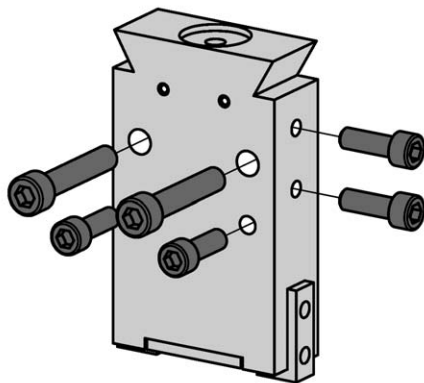

Mount up to Main body utilizing Tapped holes
located on back, front, and side of unit. Mount
thru unit with provided Clearance holes.

Utilizes integrated Dovetail in
body for precision location
and mounting

TOOLING

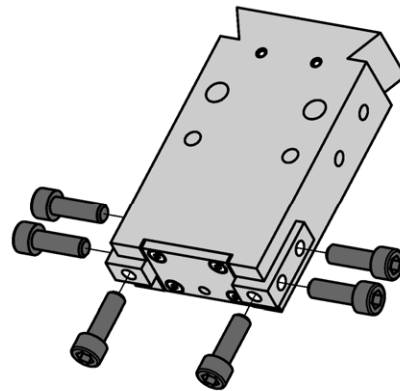

Mount tooling to fingers using
Tapped holes

Key tooling to precision ground
fingers for positive location.

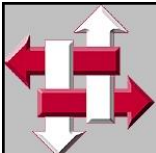

R&I
MANUFACTURING CO.

DURA-GRIP
PARALLEL GRIPPER

PH-20

DIMENSIONAL DRAWING

SPECIFICATIONS

	PH-20	MPH-20
Standard Grip Force @ 100 psi [7 bar] *	9 lbf	40 N
Standard Stroke	0.26 in	6.6 mm
Base Weight	0.29 lbs	0.13 kg
Unit Displacement (grip and release)	0.06 in ³	0.95 cm ³
Cylinder Bore Diameter	0.562 in	14.3 mm
Actuation Time (no load)	0.20 sec	

* Loading between lower jaw surface - zero tooling length

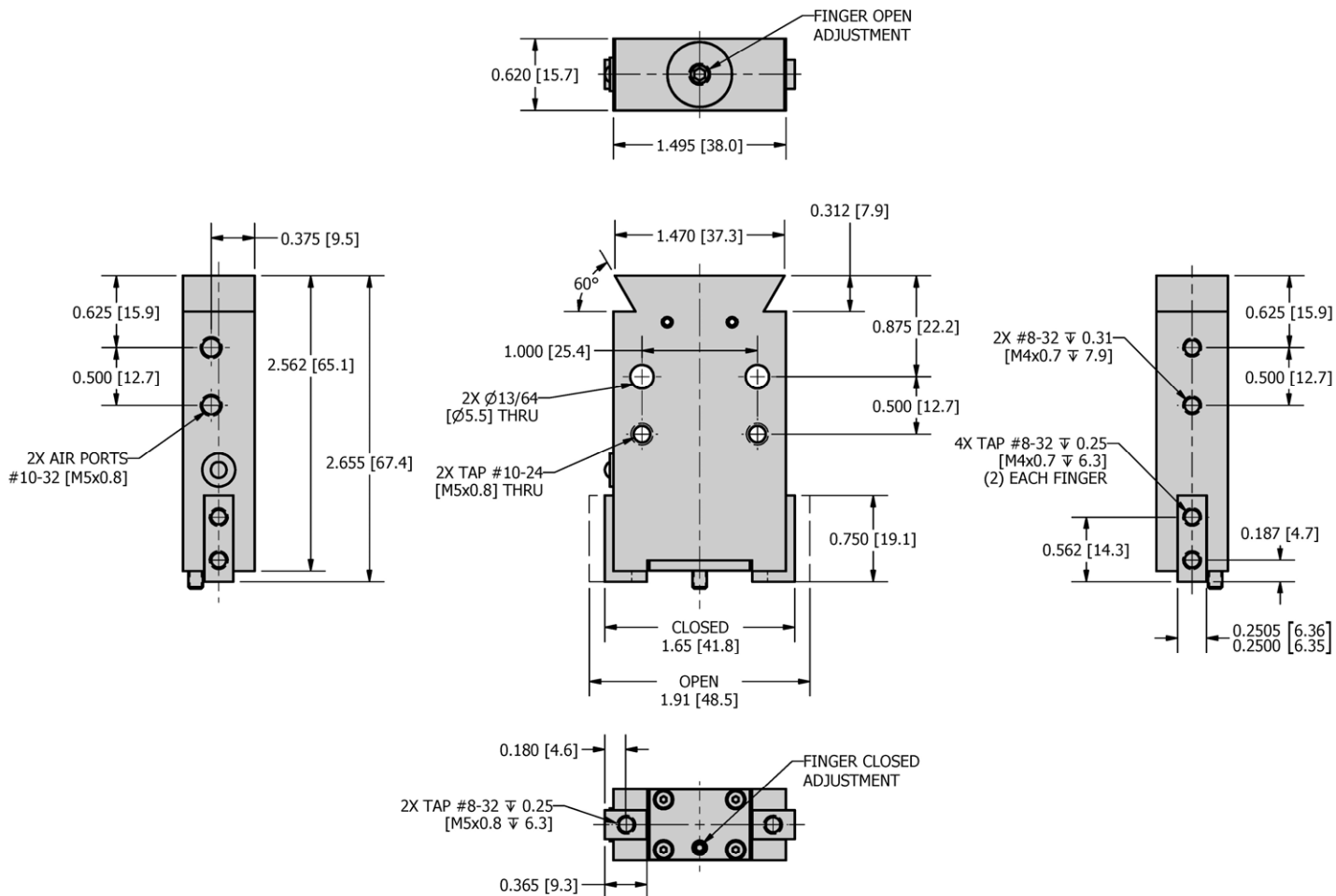

HOW TO ORDER : BASIC UNIT

METRIC TOP CAP STYLE

M **PH-20** - **V**
SEALS

METRIC M

SEALS V - Viton (standard Buna - N)

SAMPLE ORDER: PH-20-V

Ex) PH-20 with Viton Seals

**CUSTOM DESIGNS ALWAYS AVAILABLE
PLEASE CONTACT US FOR INFORMATION**

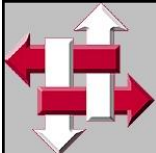

ADDITIONAL MOUNTING INFORMATION

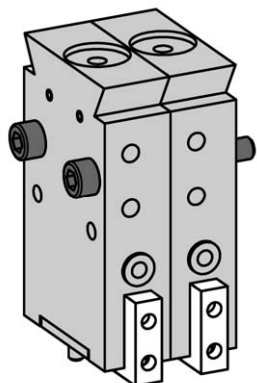

STACKABLE DESIGN

Use the Clearance holes to stack 2 or more gripping heads together.

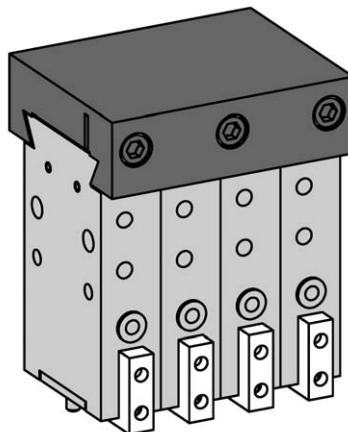

Use the DP-21 Universal Dovetail receiver to accurately hold and locate up to 4 PH-20 grippers. The DP-21 can then be modified to suit your application

See **DURA-GRIP ACCESSORIES** Page for the **DP-21** Universal Dovetail receiver

Page **1-3.1**

ADDITIONAL INFORMATION

LOADING	PH-20		PH-20	
	Static	Dynamic	Static	Dynamic
Max Force F	50 lbf	10 lbf	222.3 N	44.5 N
Max Moment M_x, M_z, M_y	50 lbf-in	10 lbf-in	5.6 N-m	1.1 N-m

NOTE: Loading based on utilization of both fingers.

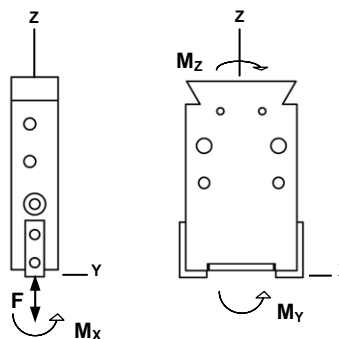

GRIP FORCE

The maximum capacity of the gripper is a function of many variables and will change based on the shape of the part, surface finish, accelerations during transfer, the shape of the finger tooling, and air pressures. Use the Grip force calculated below *and* the application variables to determine the proper sizing of the gripper.

The Grip force - **F** is defined as the maximum force that can be applied to the fingers without moving. The force is analytically determined and will vary slightly with friction.

English **GRIP FORCE - F (lbf) = P_{AIR} (psi) x G_F x T_F**

Metric **GRIP FORCE - F (N) = P_{AIR} (bar) x G_F x T_F**

GRIP FACTOR G_F		PH-20	MPH-20
Standard Unit	EXTERNAL	0.091	5.87
	INTERNAL	0.073	4.71

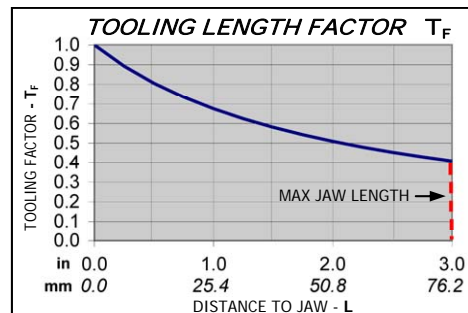
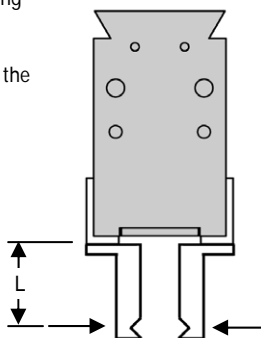

GRIP FORCE

P_{AIR} = Air Pressure
G_F = Grip Factor (see chart)
T_F = Tooling Factor (see graph)



It is recommended that finger tooling be designed to encompass the part as the grip force requirement is lower. If the grip cannot be performed by encompassing the part and a friction grip must be performed, always use a factor of safety of at least 4.

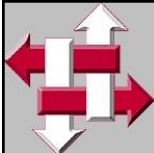

EXPLODED VIEW

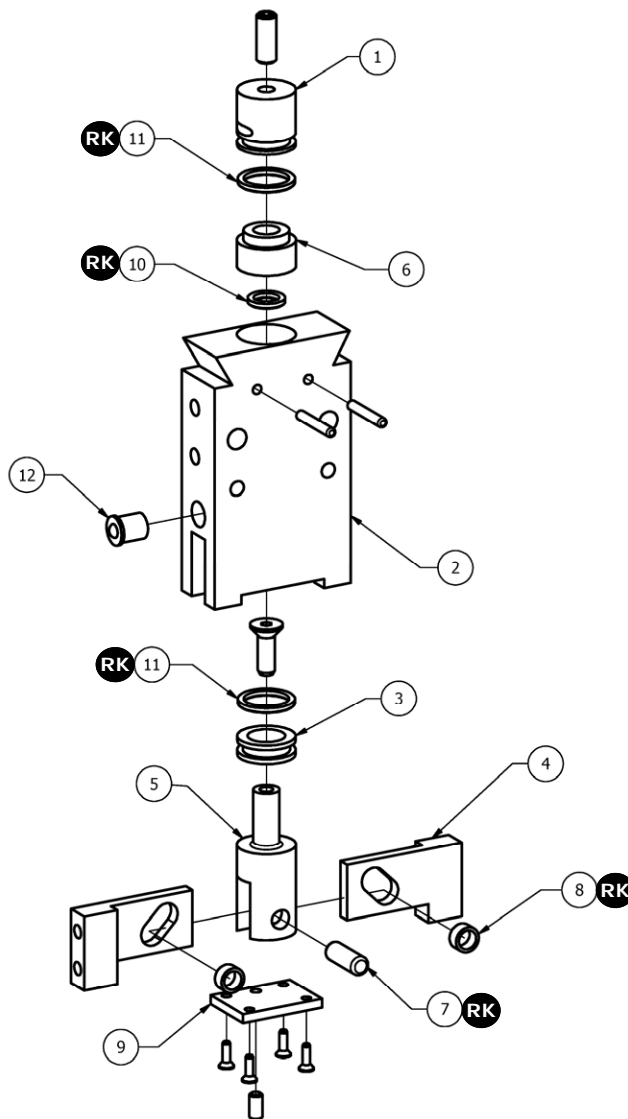

PARTS LIST

HOW TO ORDER PARTS

ITEM	REQ'D	NAME	PH-20	OPTIONS
1	1	Top Cap	RB-94-2	
2	1	Main Body	PH-20-2	
3	1	Piston	PH-20-3	
4	2	Finger	PH-20-4	
5	1	Piston Shank	PH-20-5	
6	1	Cylinder Bushing *	PH-20-6	
7	1	Pin *	PH-40-7	
8	2	Roller *	PH-20-8	
9	1	Bottom Cap	PH-20-9	
10	1	Piston Shank Seal *	ORG-010	-V ¹
11	2	Top Cap & Piston Seal *	ORG-013	-V ¹
12	1	Oiler *	OIL-250	
RK	1	Repair Kit * #	PH-20-RK	-V ¹

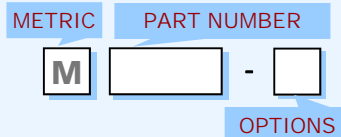

SAMPLE ORDER: PH-20-4

Ex) PH-20 Finger

OPTIONS (see product pages for information)

¹ - V = Viton

NOTES

* - Metric code not required

- Repair Kits include req'd qty of parts marked with RK

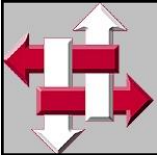

R&I
MANUFACTURING CO.

TECH NOTES

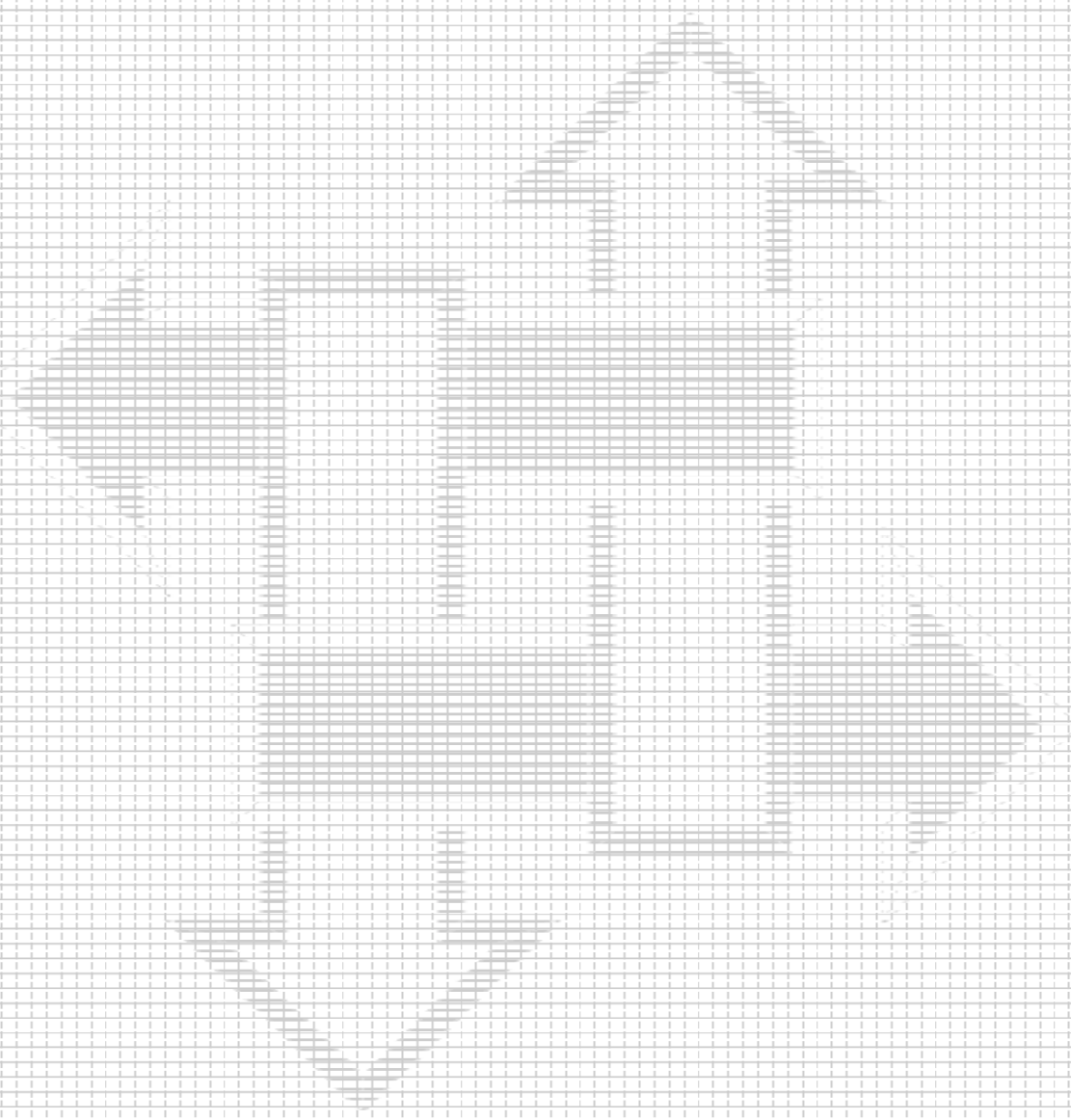



JF-20 - WIDE BODY

DURA-GRIP JF-20 Linear Gripping Device is designed to provide a low cost wide body gripper with the capability of handling large parts. The device can be used as part of a transfer mechanism or utilized at an assembly station to hold a work piece in place. Parts can be gripped internally or externally and the end blocks provide the tool engineer with several options for mounting the gripping fingers. The air operated unit is compact with operation controlled through a four-way air valve.

QUALITY CONSTRUCTION

DURA-GRIP JF-20 main block provides the fixed support with mounting holes provided on the top and both sides of the block. The unit can be mounted in any plane. Both end blocks are machined on three sides to accept tooling with each block pinned to one of the ground steel rods. Slide rods are parallel to the mounting surface within .002" per foot. They are mounted on oil impregnated bronze bushings. Bushings are utilized rather than linear ball bearings because bushings distribute the load over a larger surface area resulting in less wear on the slide rods. The unit has been tested under actual operating conditions with up to 160 million inches accumulated travel with negligible wear. Stroke adjustment screws are included for separate adjustment of endblocks in closed and open positions.

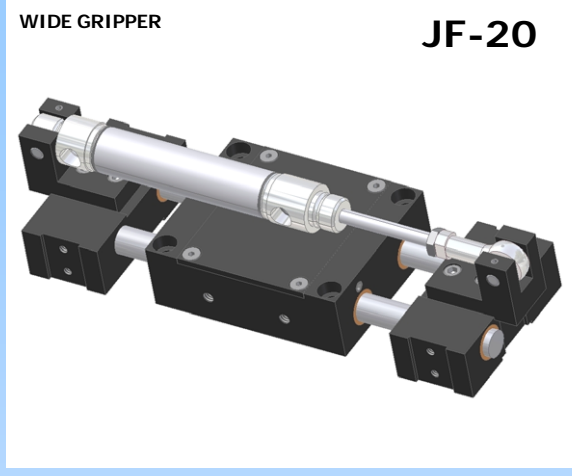

Use the JF-20 Parallel Gripper wherever you need durable and precise part placement with large work envelope.

TECHNICAL SPECIFICATION

Pneumatic Specifications	ENGLISH	METRIC
Pressure Range	40-100 psi	3-7 bar
Required Valves	4-way, 2 position	
Temperature Range		
Buna-N Seals (standard)	-30 to 180 F	-35 to 80 C
Viton Seals (-V option)	-20 to 300 F	-30 to 150 C

Construction	
Travel Tolerance	+0.005" / - 0.005" [+0.13 / 0.130mm]
Cylinder Type	Double Acting
Dynamic Seals	Buna-N
Maintenance	Field Repairable

OPERATING PRINCIPLES

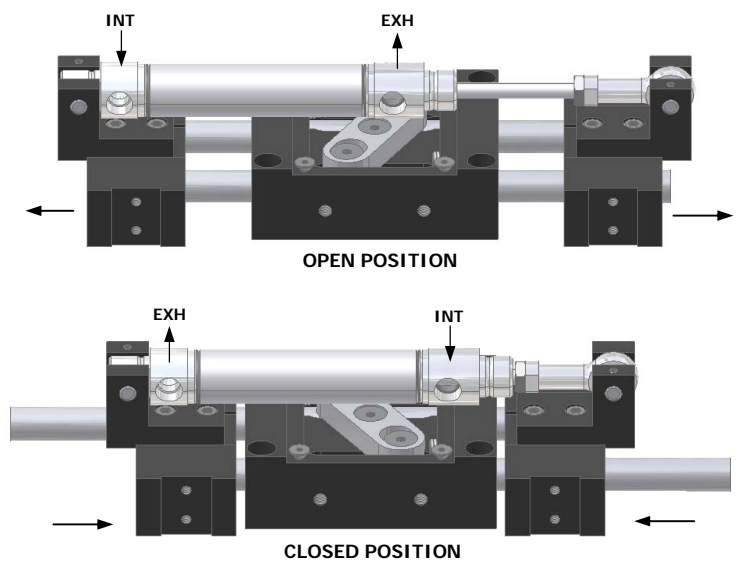

- Air pressure drives a double acting cylinder directly connected to each endblock
- Each endblock is pinned to one rod, the other rod slides through opposing endblock
- Rods are connected via a hardened steel link to produce synchronized endblock motion.

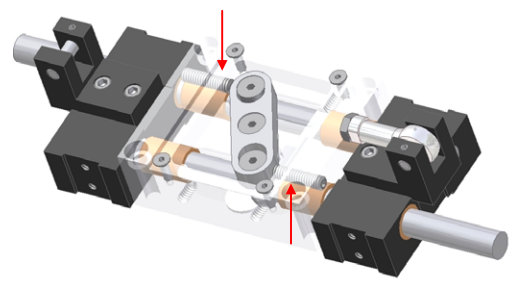

Closed and open position can be adjusted with set screws located in the Main body of the unit. The set screws act directly on the link.

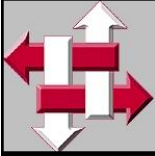

PRODUCT FEATURES

- Aircraft Grade Aluminum
2024 with black anodize
- Simple and Highly Durable
Time tested, field approved design
- High Grip Force
High gripping force-to-weight ratio

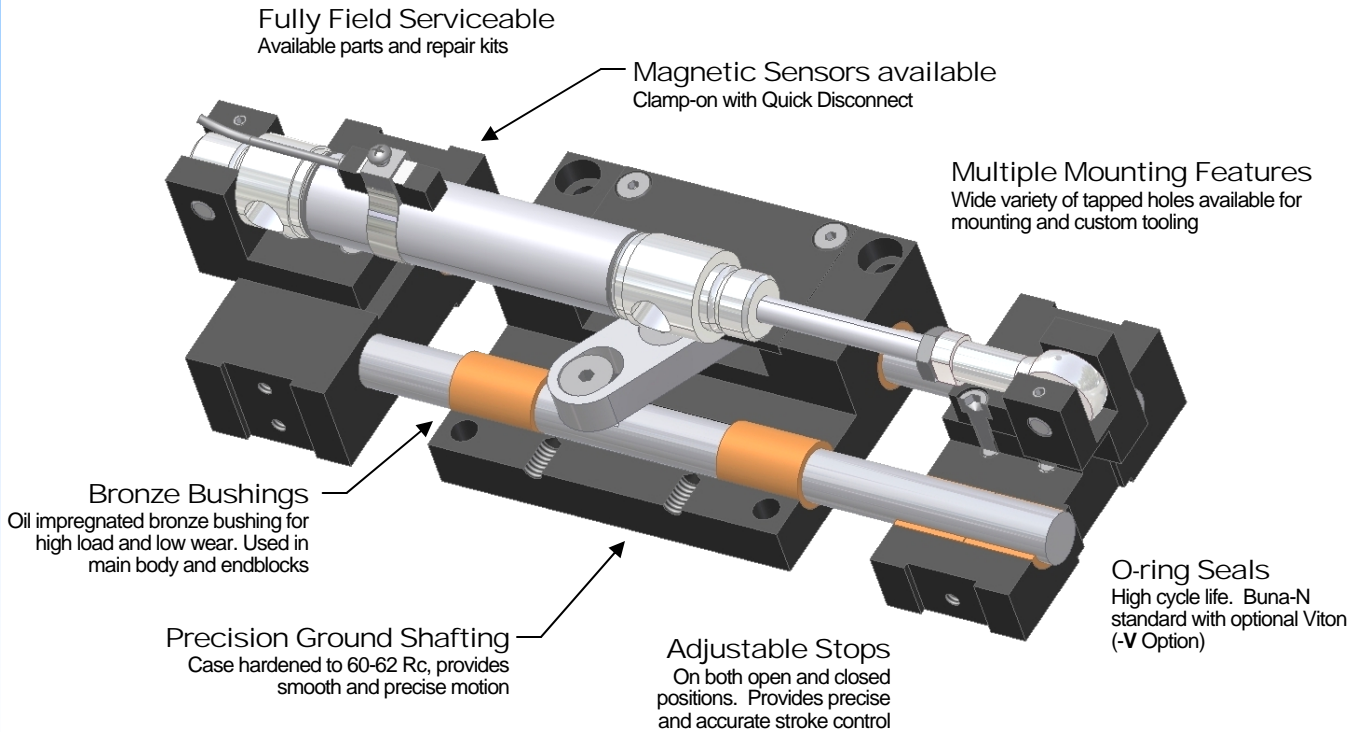

DESIGNED - MANUFACTURED - ASSEMBLED IN THE USA

MOUNTING INFORMATION

Mounts and operates in any orientation

MAIN BODY

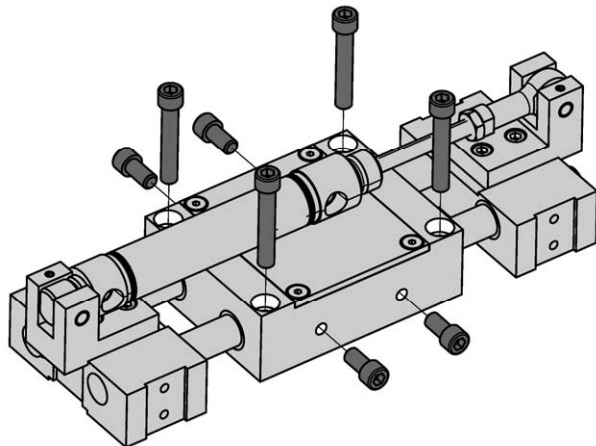

Mount up to Main body utilizing Tapped holes located on both sides of unit. Mount thru unit with provided Clearance holes.

TOOLING

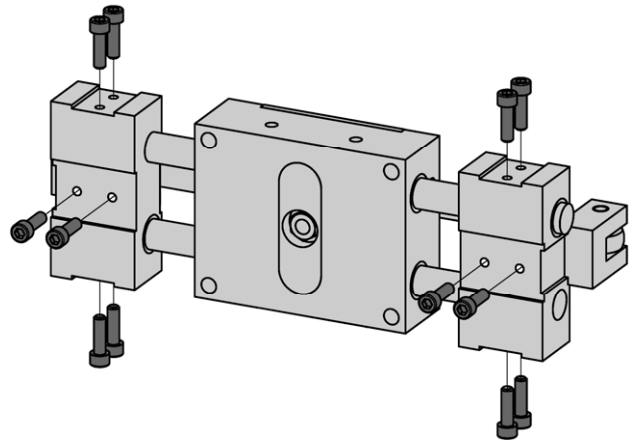

Mount tooling to bottom or sides of endblocks utilizing Tapped holes.

Key tooling to slots in endblocks for positive location.

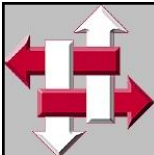

R&I
MANUFACTURING CO.

DURA-GRIP

WIDE BODY
PARALLEL GRIPPER

JF-20

DIMENSIONAL DRAWING

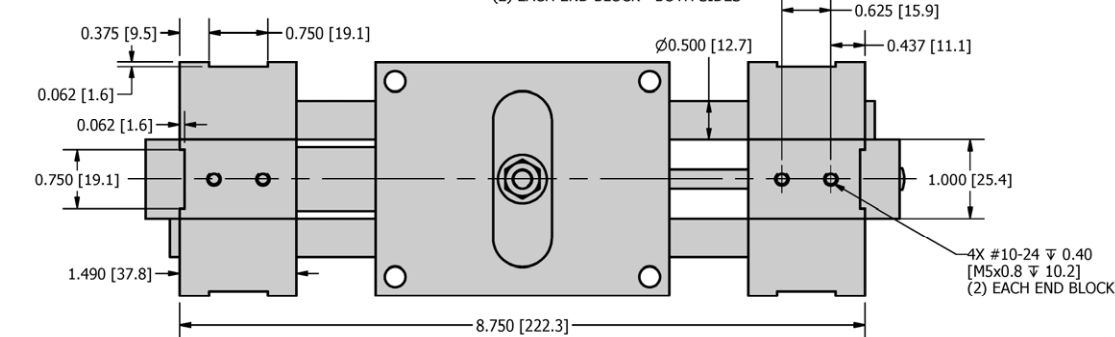
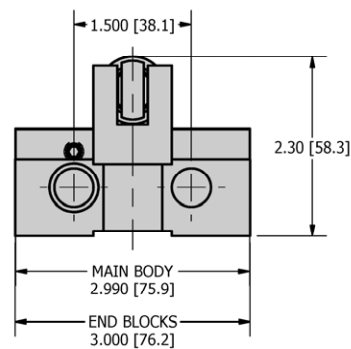
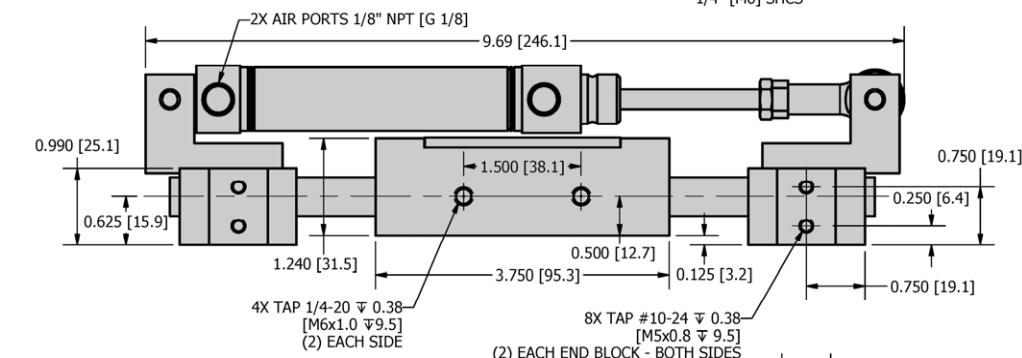
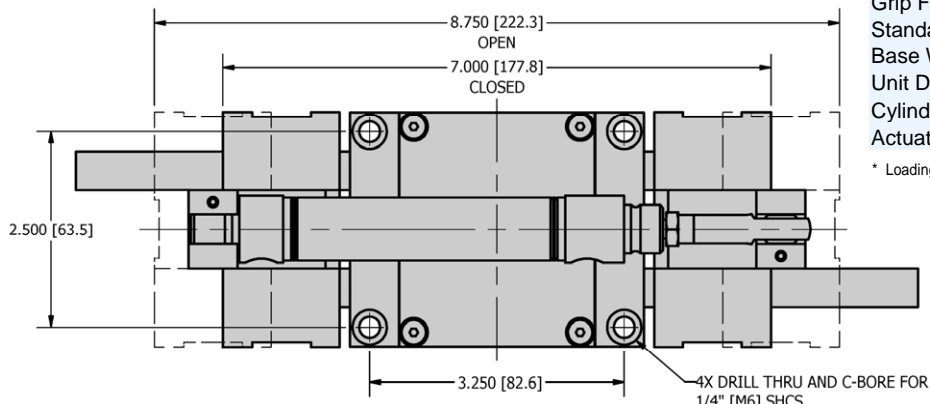

SPECIFICATIONS

	JF-20	MJF-20
Grip Force @ 100 psi [7 bar] *	33 lbf	147 N
Standard Stroke	1.750 in	44.5 mm
Base Weight	3.75 lbs	1.70 kg
Unit Displacement (grip / release)	1.46 in ³	23.9 cm ³
Cylinder Bore Diameter	0.750 in	19.05 mm
Actuation Time (no load)	0.40 sec	

* Loading at bottom jaw surface - external grip

HOW TO ORDER : BASIC UNIT

ACCESSORIES (order separately)

METRIC BASE MODEL SENSORS

M **JF-20** - **V** - **RM**

SEALS

METRIC M

SEALS V - Viton (standard Buna - N)

SENSORS RM - Magnetic Sensor Ready

Includes Piston Magnet . Sensors sold separately - see Magnetic Sensors

SAMPLE ORDER: JF-20-V

Ex) JF-20 with Viton Seals

MAGNETIC SENSOR KITS * (Cylinder clamp mounted)

CSK-N - Magnetic Sensor NPN w/ quick disconnect Kit

CSK-P - Magnetic Sensor PNP w/ quick disconnect Kit

CSK-R - Magnetic Sensor REED output w/ quick disconnect Kit

* Requires sensor ready (-RM). Sensor kits include (2) sensors and (2) 5 meter cables.

MAGNETIC SENSORS * (Cylinder clamp mounted)

CS-N - Magnetic Sensor NPN w/ quick disconnect

CS-P - Magnetic Sensor PNP w/ quick disconnect

CS-R - Magnetic Sensor REED output w/ quick disconnect

* Requires sensor ready (-RM). Includes (1) sensor.

SENSOR CABLE

SENCAB-5 - Quick Disconnect PUR Cable 5M Length

**CUSTOM DESIGNS ALWAYS AVAILABLE
PLEASE CONTACT US FOR INFORMATION**

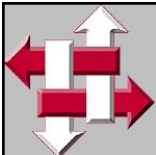

ADDITIONAL INFORMATION

LOADING	JF-20		M JF-20	
	Static	Dynamic	Static	Dynamic
Max Force F	100 lbf	20 lbf	444.5 N	88.9 N
Max Moment M_x, M_y	125 lbf-in	30 lbf-in	14.1 N-m	3.4 N-m
Max Moment M_z	200 lbf-in	65 lbf-in	22.6 N-m	7.3 N-m

NOTE: Loading based on utilization of both endblocks.

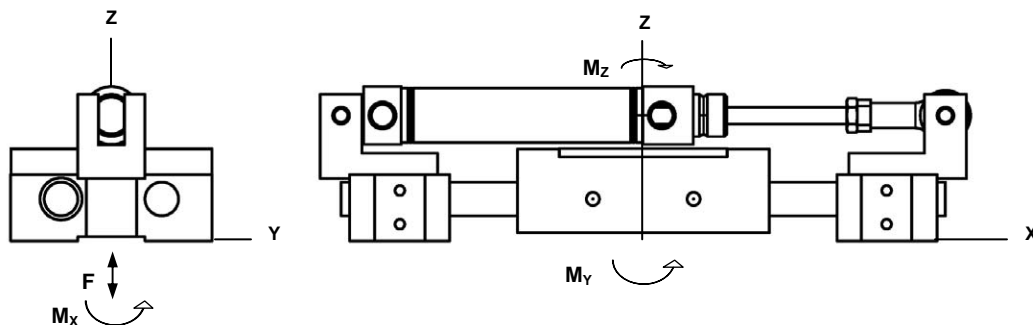

GRIP FORCE

The maximum capacity of the gripper is a function of many variables and will change based on the shape of the part, surface finish, accelerations during transfer, the shape of the finger tooling, and air pressures. Use the Grip force calculated below *and* the application variables to determine the proper sizing of the gripper.

The Grip force - **F** is defined as the maximum force that can be applied to the end blocks without moving. The force is analytically determined and will vary slightly with friction.

GRIP FACTOR G_F	JF-20	MJF-20
	Standard Unit	
EXTERNAL	0.333	21.47
INTERNAL	0.374	24.15

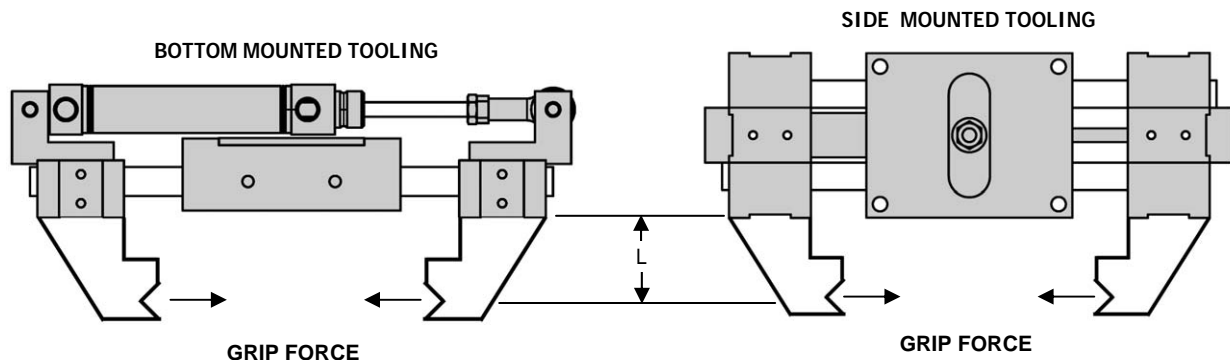
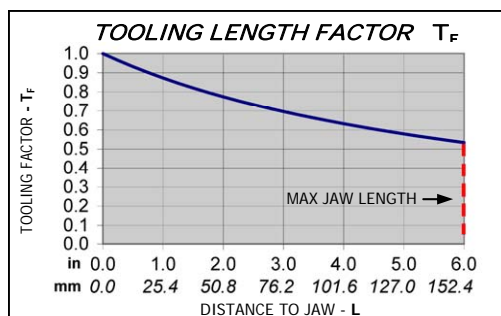

English **GRIP FORCE - F (lbf) = P_{AIR} (psi) x G_F x T_F**

Metric **GRIP FORCE - F (N) = P_{AIR} (bar) x G_F x T_F**

P_{AIR} = Air Pressure
G_F = Grip Factor (see chart)
T_F = Tooling Factor (see graph)



It is recommended that finger tooling be designed to encompass the part as the grip force requirement is lower. If the grip cannot be performed by encompassing the part and a friction grip must be performed, always use a factor of safety of at least 4.

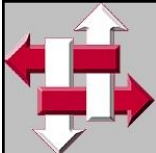

R&I
MANUFACTURING CO.

DURA-GRIP

WIDE BODY
PARALLEL GRIPPER

JF-20

EXPLODED VIEW

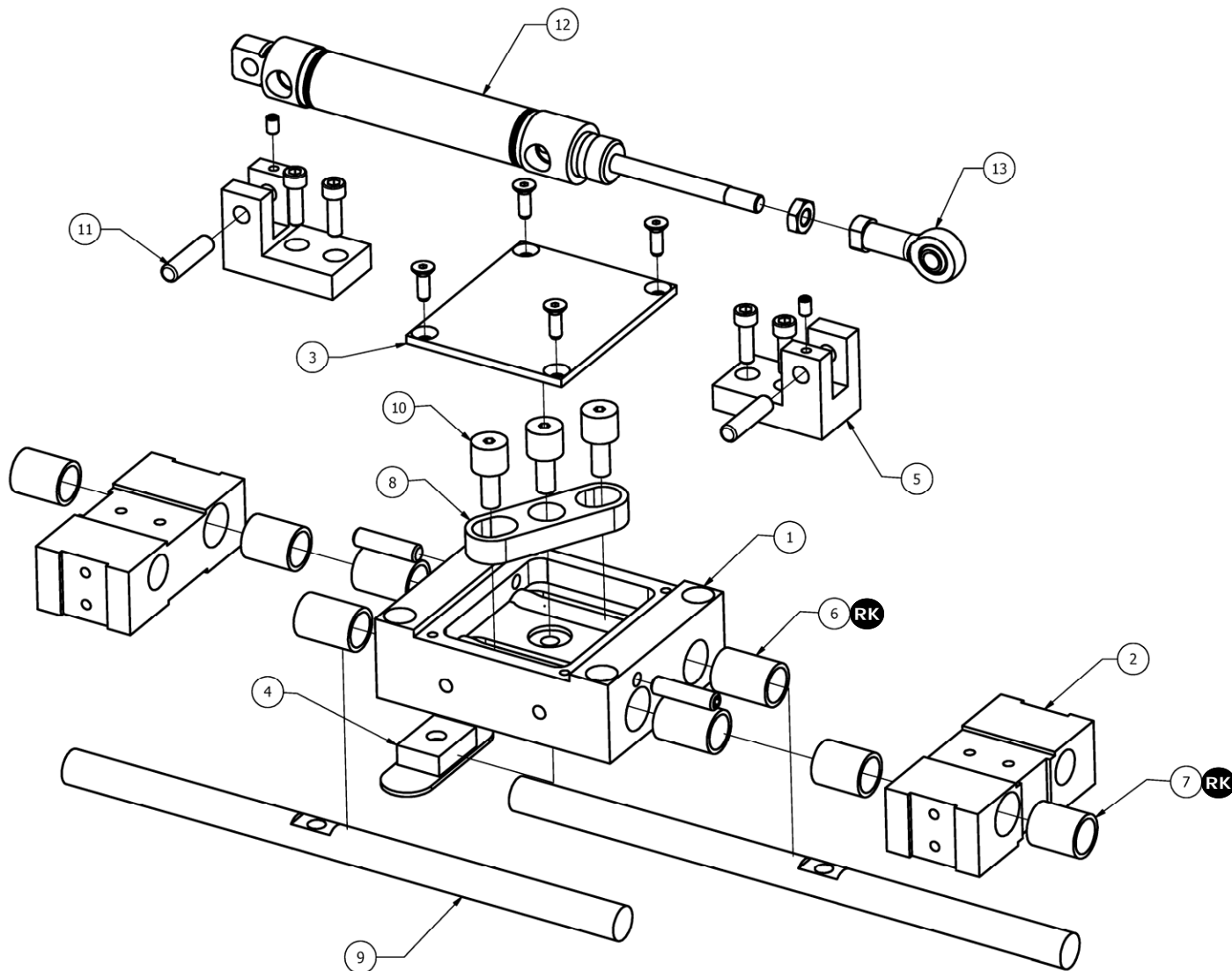

PARTS LIST

HOW TO ORDER PARTS

ITEM	REQ'D	NAME	JF-20	OPTIONS
1	1	Main Body	JF-20-1	
2	2	End Block	JF-20-2	
3	1	Top Cover	JF-20-3	
4	1	Bottom Cover	JF-20-4	
5	2	Bracket	JF-20-5	
6	4	Main Body Bushing *	JF-20-6	
7	4	End Block Bushing *	JF-20-7	
8	1	Link *	JF-20-8	
9	2	Rod *	JF-20-9	
10	3	Cam Follower *	CF-350	
11	2	Pivot Pin *	FPP-305	
12	1	Air Cylinder *	DXP-75	-V ¹ -RM ²
13	1	Rod End *	RE-200	
RK	1	Repair Kit * #	JF-20-RK	-V ¹

METRIC

PART NUMBER

M

[] - []

OPTIONS

SAMPLE ORDER: JF-20-8

Ex) JF-20 Link

OPTIONS (see product pages for information)

1 - V = Viton

2 - RM = Magnetic Sensor Ready

NOTES

* - Metric code not required

- Repair Kits include req'd qty of parts marked with RK